

BB-2/3T

Bottom Belt Case Taping System

User Guide

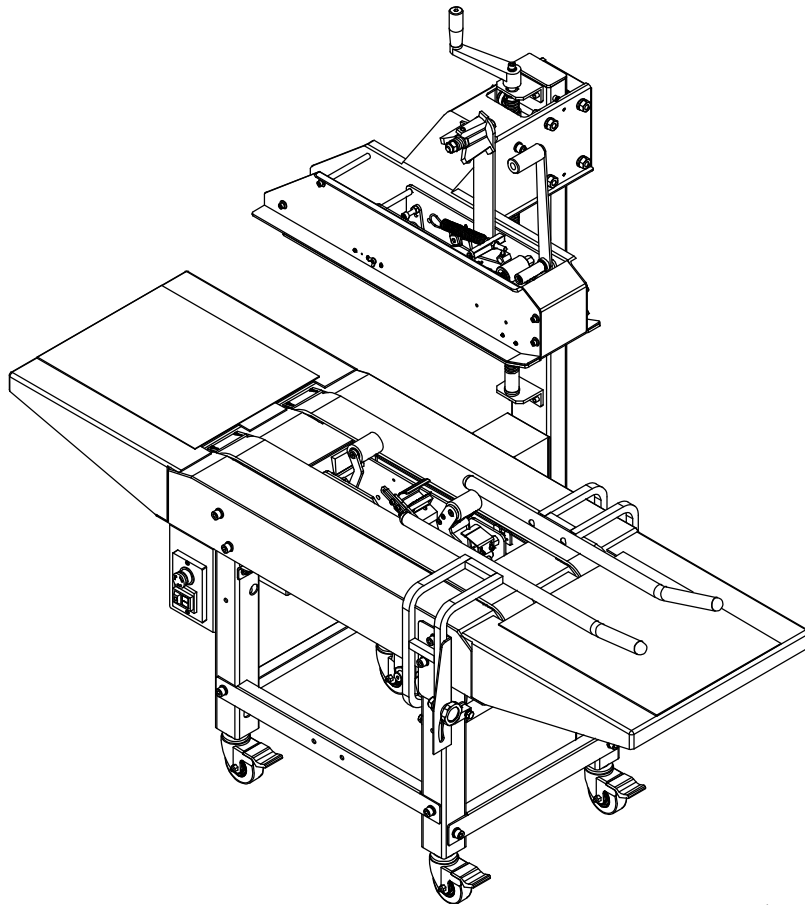

EASTEY[®]

BB-2/3T

Bottom Belt Case Taping System

User Guide

Revised 06/25/2019

P/N 5000787 Rev. D

Copyright and Trademarks

Copyright ©2015-2019 Engage Technologies Corporation
All rights reserved. All trademarks and brand names
are the property of their respective owners.

Eastey
7041 Boone Ave. N.
Brooklyn Park, MN 55428

Phone: (763) 428-4846; Fax (763) 795-8867; 1-800-835-9344

www.eastey.com

Contents:

- Safety 7**
- Introduction 8**
 - BB-2/3T Case Taper Overview 8
 - Specifications 9
 - Dimensions 10
- Installation 11**
 - Install Casters 11
 - Set Machine Height..... 11
 - Location Requirements 12
 - Install Front and Rear Tables 13
 - Next Steps..... 14
- Operation 15**
 - Load Tape 15
 - Check Tension 16
 - Thread Tape..... 16
 - Main Spring..... 18
 - Control Panel 19
- Adjustments 20**
 - Box Width and Height Adjustment..... 20
 - Guide Rail Adjustment 21
 - Top Tape Head Height Adjustment 22
 - Belt Adjustment 23
- Maintenance 24**
 - Rollers..... 24
 - Cutting Knives 24
 - Changing Drive Belts 25
- Troubleshooting..... 28**
- Parts List..... 30**
 - Electrical..... 30
 - Machine Body and Tables..... 32
 - Mast and Upper Tape Head Seat 35
- Appendix A: Electrical Schematic 37**
- Warranty Statement 38**
- Customer Support..... 40**

Safety

Safety Precautions

Before installing, operating or servicing this equipment, please read the following precautions carefully:

- This machine is equipped with moving belts. Do not place hands near the belts when they are moving, as fingers may be pinched where belts descend under the exit table or into the frame. Always remove boxes from the exit table after they clear the exit end of the conveyor.
- Observe caution when near tape heads or when threading tape. The tape cutting knives are very sharp, automatically operated, and linked to the wipe down rollers.
- Always disconnect power before attempting maintenance for any electrical or moving parts. Do not attempt to open or work on the electrical box, junction boxes, or other electrical components of the unit without first disconnecting power to the machine. Electrical shock hazard exists if power is not disconnected.
- Use only the specified power-supply cable. Do not use the power cable to pull or position the machine, as this will damage or break the cable.
- Do not bypass any factory-designed safety features such as knife guards, interlocks, switches, etc. Do not operate the machine if such modifications have been made.
- Do not attempt to operate the machine with loads that exceed the limits of use and operation in regards to weight and sizes, or with unstable loads that present a hazard of tipping or falling.
- This equipment is designed for indoor operation in a typical clean, dry factory environment. Do not operate the machine in any extremely wet or oily environment that may exceed operating specifications.
- Do not place hands, head, or any part of the body inside the confines of the machine unless the tape head mechanisms are securely fastened, and the electrical supply is shut off.
- To minimize the potential for personal injury, always be sure that the machine operators and others working on the machinery are properly trained in the correct usage of the equipment and properly instructed regarding operation.
- Never provide service or clear a box jam while the machine is running. Always stop the machine and shut off power before servicing.
- When feeding a box into the unit, always hold down the box top and present the box to unit. Release hands as soon as the belts begin to take the box.
- Do not wear loose clothing such as ties, scarves, jewelry, etc. Long hair should be pulled back and/or covered while operating this machine.

Introduction

BB-2/3T Case Taper Overview

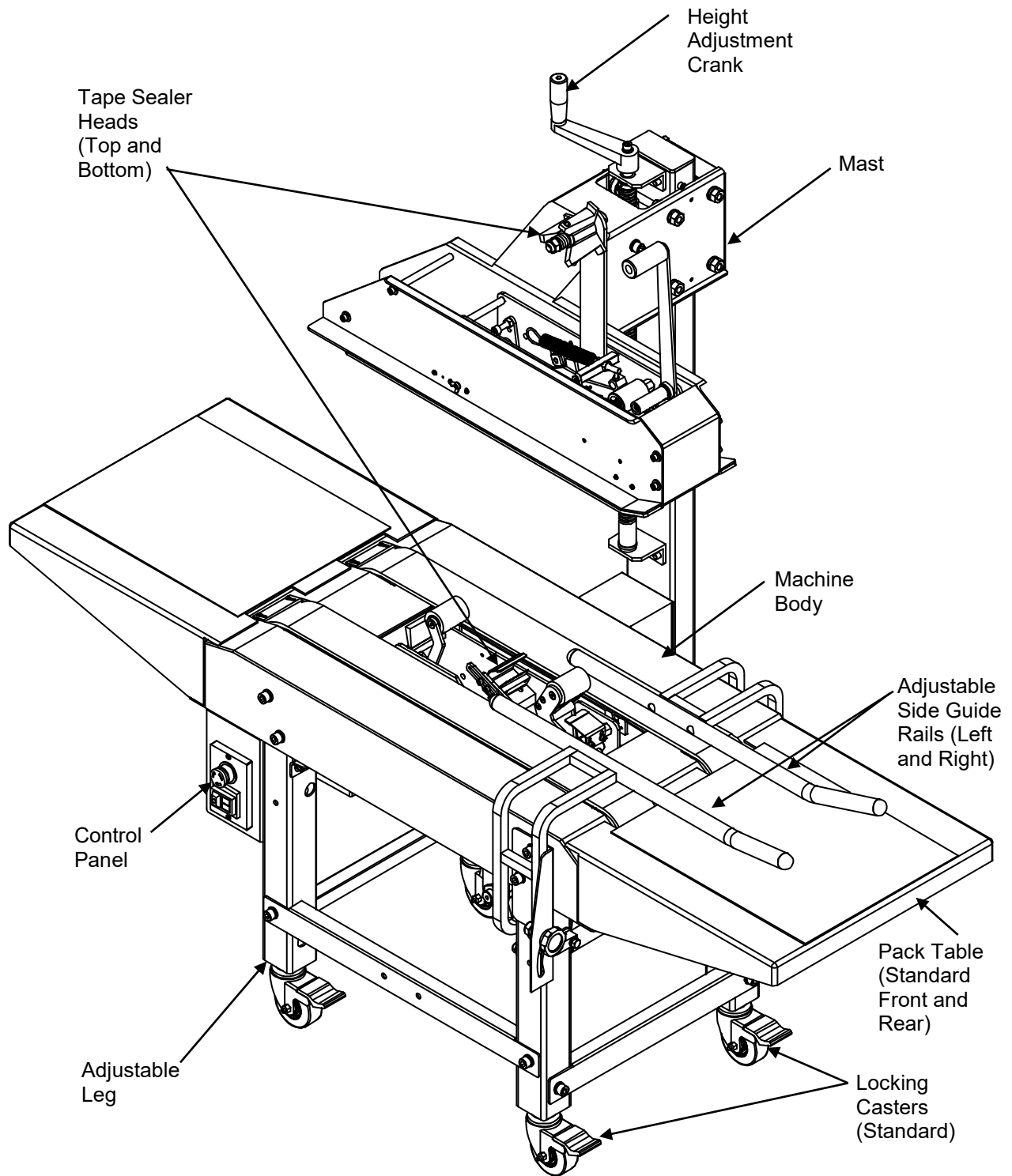

Specifications

Model	BB-2T
Tape	2 inches (50 mm) tape width, up to 15 inches (36 cm) diameter rolls
Belt Speed	60 feet/min (19 m/min)
Capacity	(L) 6 inches (15 cm) to unlimited (W) 6 to 21 inches (15 to 53.3 cm) (H) 4 to 20.5 inches (10 to 52 cm)
Conveyor Height Adjustment	21.3 to 27.2 inches (54.1 to 69.1 cm) without casters 25.8 to 31.7 inches (65.5 to 80.5 cm) with casters
Electrical Requirements	110 VAC, 60 Hz, 6A
Power Consumption	200 W
Air Requirements	None
Machine Size	(L) 64 inches (162 cm) (W) 28 inches (79 cm) (H) 56.75 inches (144 cm) without casters (H) 60.6 inches (154 cm) with casters
Sound Level	60 dB
Machine Net Weight	260 lbs.

Options

- 3 inch Tape Head — Accepts three inch wide tape rolls. (BB-3T)
- Top Squeezer — Designed to stabilize the box and push top flaps together for easier taping.

Dimensions

Dimensions shown are in inches.

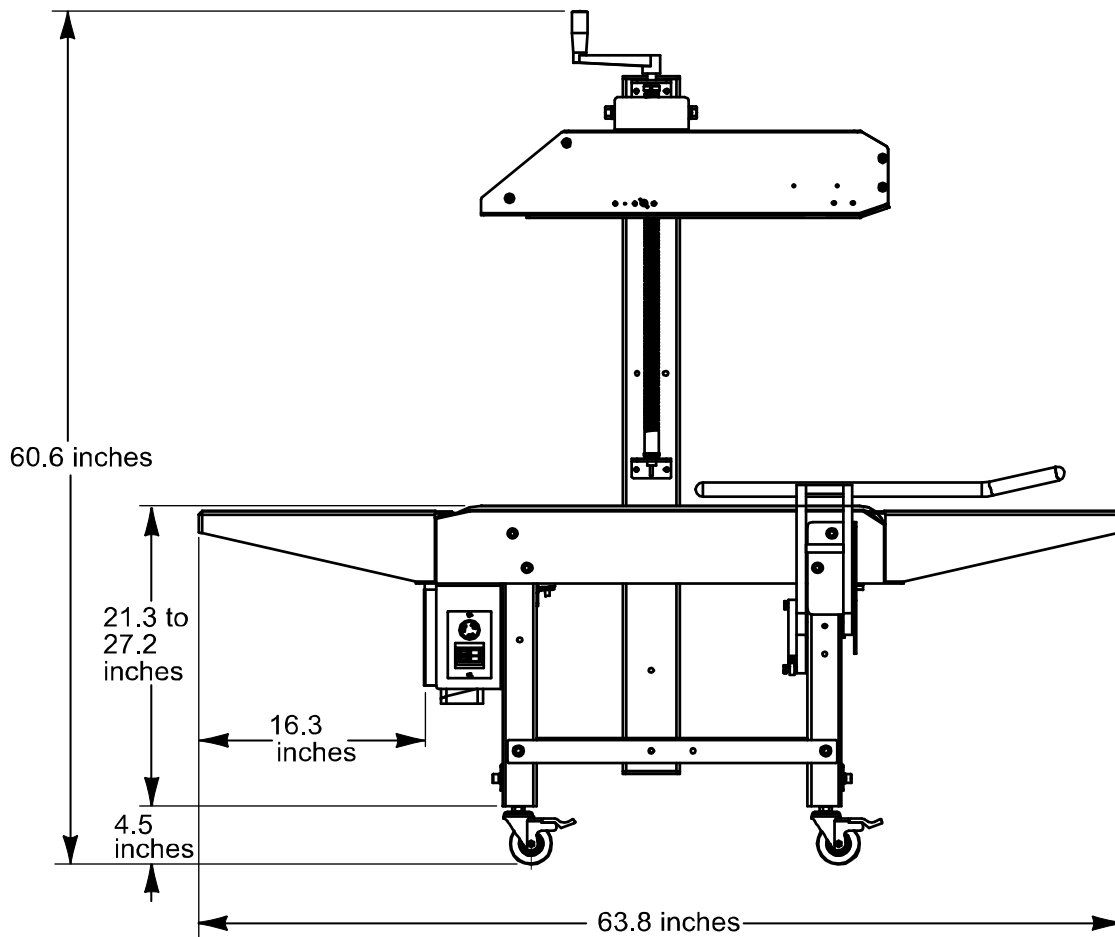
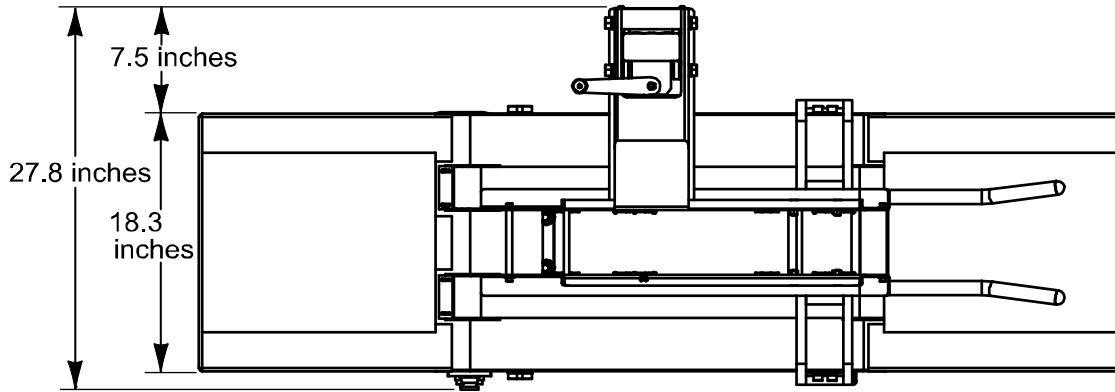

Installation

The BB-2/3T Case Taper is shipped boxed and mounted on a shipping pallet. The case taper is mostly assembled with the exception that the front and rear tables and casters and any optional components such as top squeezers are not attached.

Remove the cardboard packaging from the machine and lift the machine up and off of the shipping pallet.

CAUTION! The BB-2/3T Case Taper is heavy and will require a forklift, floor crane, or several people to move safely off the shipping pallet. Use proper equipment when lifting the case taper and ensure the case taper is secure and will not shift while being moved or during height adjustment and caster installation.

Install Casters

Four locking casters are provided standard with the BB-2/3 Case Taper and may be installed if preferred. To install the locking casters, thread a caster into the bottom of the adjustment insert at the bottom of each leg as shown at left below and tighten the nut (A) to affix the caster in place.

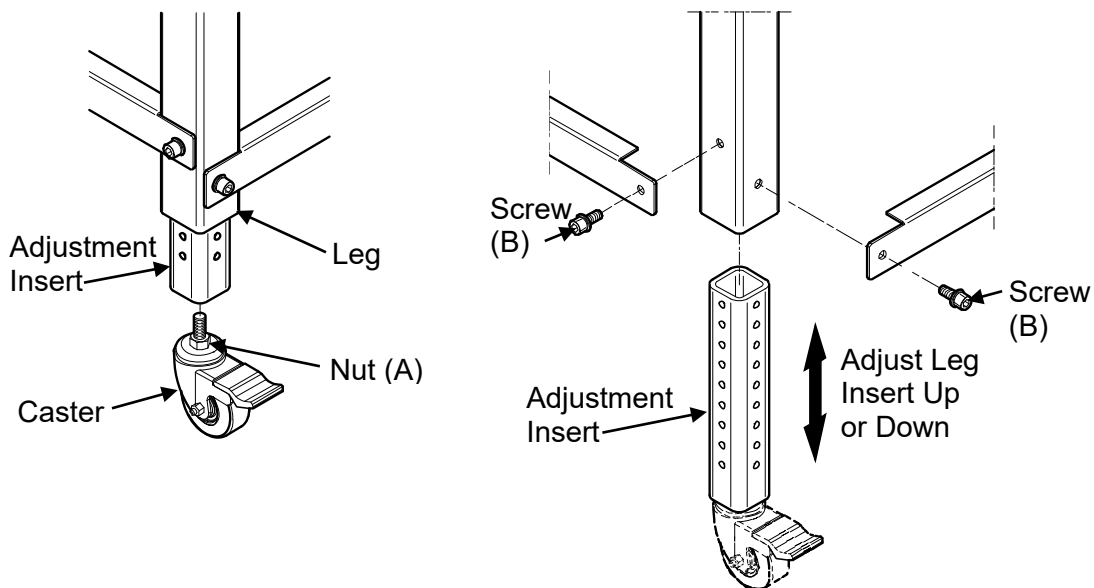

Set Machine Height

To adjust the leg height, loosen the screws (B) on each leg, slide the insert up or down (as shown at right above) to the required height, and then re-fasten the screws (B).

Move Taper To Required Location

CAUTION! If the case taper must be lifted for moving, use proper equipment when lifting and moving the case taper to ensure the case taper is secure and will not shift.

Set up the case taper and move it to its location. The casters allow easy movement over smooth flat surfaces. If you need to lift the unit to move it, you will need to use a pallet jack, floor crane, or fork lift to move it to its location.

Location Requirements

When installing the BB-2/3T Case Taper please be aware of the following considerations:

1. The surface on which it is located is flat and level.
2. Conveyor or packing table height.
3. Alignment with packaging line.

When the BB-2/3T Case Taper is positioned in the operating location you will need access to:

1. Control panel switches: Emergency Stop, Start, and Stop.
2. Height and width adjustments.
3. Tape loading (Both upper and lower tape cartridges).

Packing tables are provided standard at both the in-feed and exit ends of the case taper. An operator can fill boxes and close the flaps at the in-feed table before feeding boxes into the case taper, and then pick up boxes that have been sealed from the exit pack table.

If the case taper is part of a longer packaging line, take into consideration the table and conveyor height in relation adjacent machinery.

The machine should be placed on a flat, level floor so that it does not rock or move. We recommend that the machine be securely locked in place when used.

When the case taper has been moved to its location, use the levers on the casters to lock the wheels to prevent rolling and keep the unit in place.

Install Front and Rear Tables

Front and rear tables are identical and therefore interchangeable. Temporarily loosen socket head cap screws at the locations shown in the following illustration. Align the keyhole slots in the table flanges with the loosened cap screw heads and position table with conveyor belts, then re-tighten cap screws to secure table. Install one table at each end (front and rear) of the conveyor body.

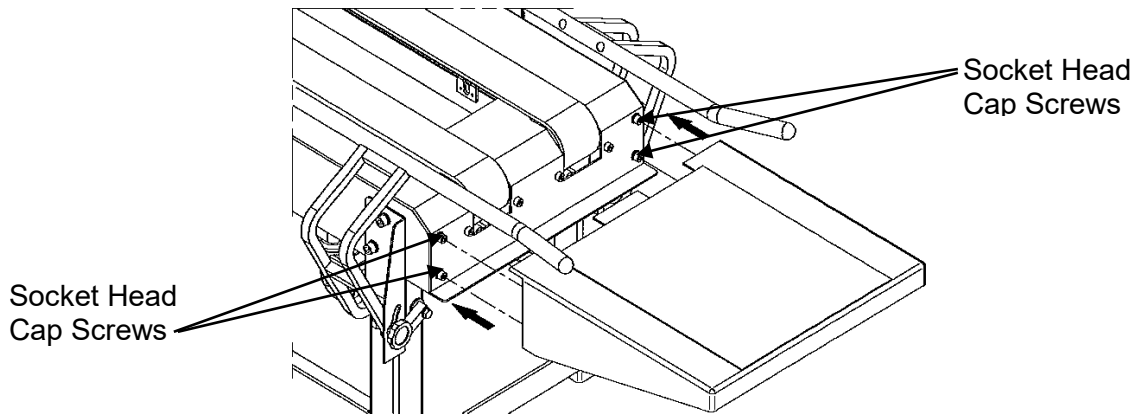

Load the tape heads with tape. (One roll each; follow instructions provided in the *Tape Cartridge User Guide*.)

Optional Mounting For Top Squeezers

Threaded holes are provided on both sides (left and right) of the case taper upper tape head seat at the locations indicated to fasten optional top squeezers to each side of the upper tape head seat assembly if they are to be installed.

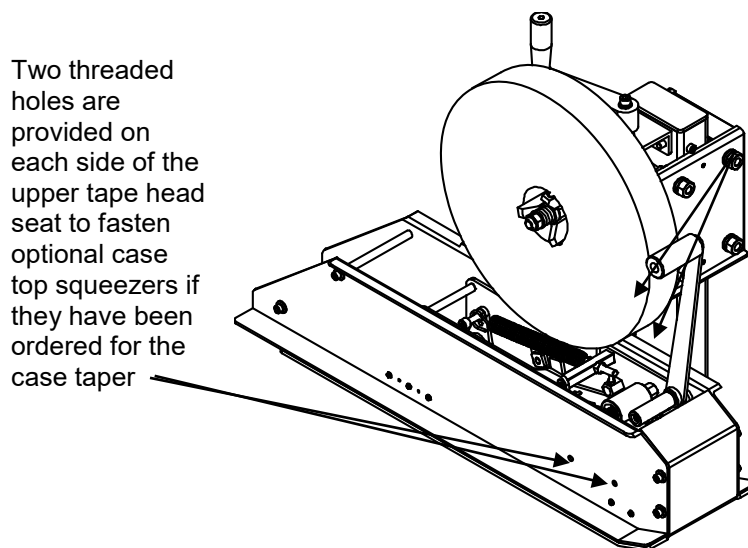

Next Steps

Follow instructions in the Operation section for instructions to load the tape cartridges in the upper and lower tape heads.

Refer to the Adjustments section for instructions to make necessary height and width adjustments that must be made for operation of the box taper.

Refer to instructions in the Operation section for instructions to power or shut down the machine.

Operation

Load Tape

Press the Stop switch and disconnect the power.

CAUTION! To avoid personal injury, remove the tape cartridge before loading tape.

When handling the tape cartridge be careful to avoid contact with the tape cutting blade.

The taping cartridge in the upper head assembly is secured in place by a single wing bolt (winged-head cap screw). Temporarily remove the wing bolt to remove the upper tape head.

After the tape head has been removed, remove core of spent tape roll (if present) and push the tape roll onto the spindle assembly.

NOTE: Make sure the tape roll is pushed all the way on the spindle assembly.

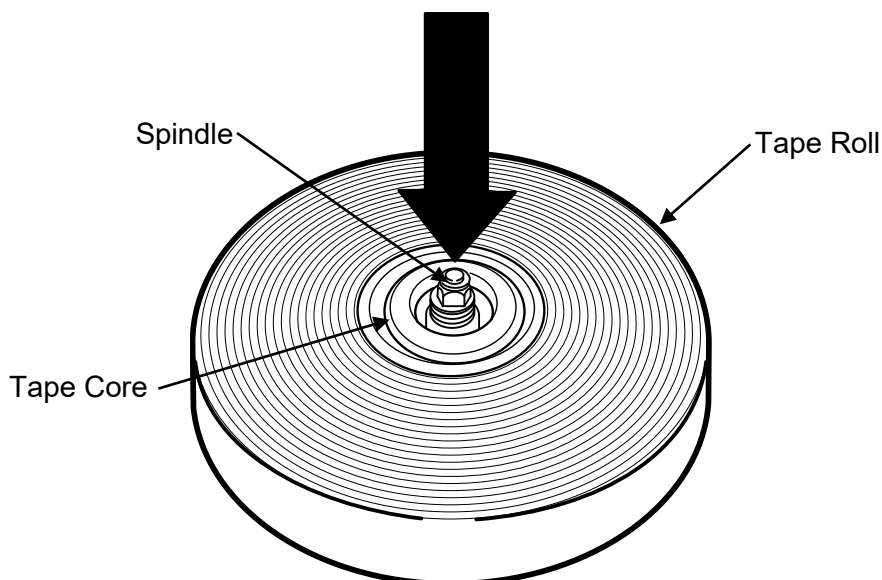

Check Tension

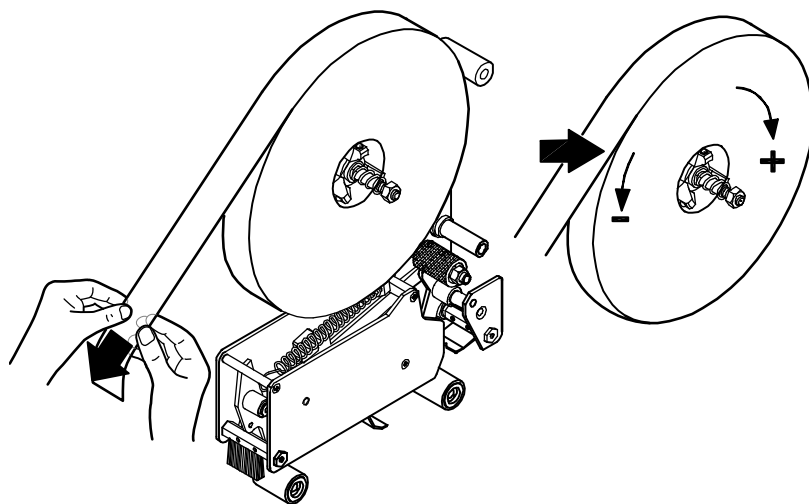

Check the tape for correct tension. Tighten or loosen the tape core holder to adjust tension.

Thread Tape

Carefully thread the new tape through the rollers in the tape head as shown in the applicable diagram in the Tape Head User Guide provided with the tape head.

For convenience, diagrams for threading tape in the Eastey-EX Tape Head and EZ-EX Tape Head are provided on the following page. Follow the diagram that applies for your tape head, depending on the tape head model and position on the taper.

Eastey-EX Tape Head

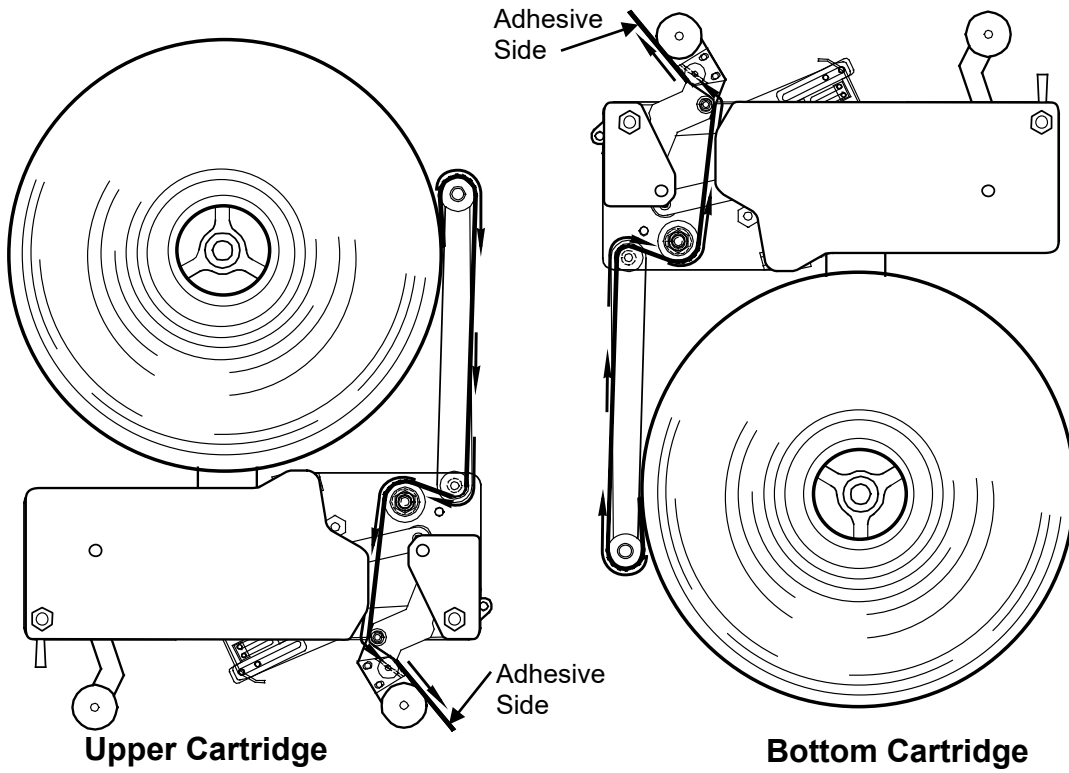

EZ-EX Tape Head

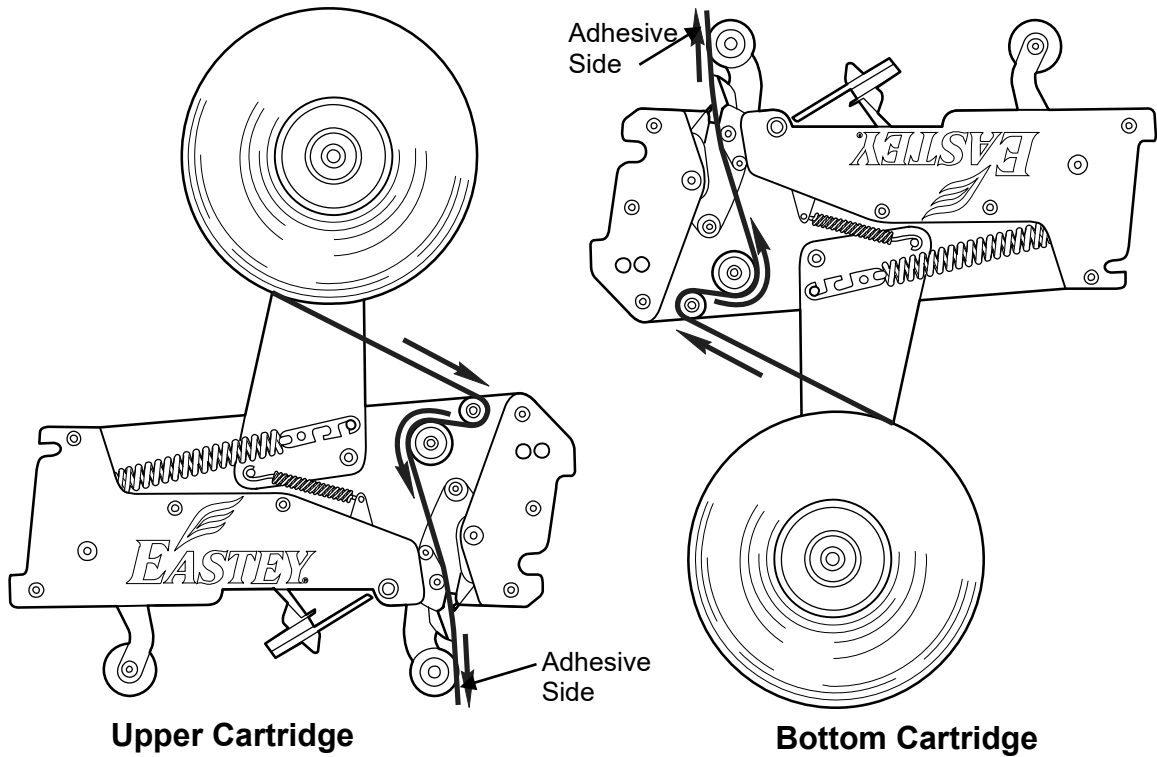

Center Tape — Eastey-EX Tape Head only

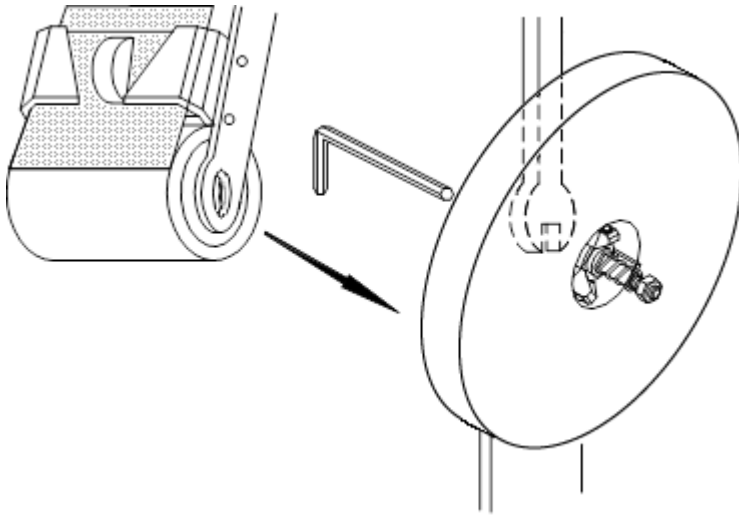

Make sure the tape is centered on all the rollers.

There are several rollers in the tape cartridge where the tape alignment should be checked to verify the tape stays on center as it is being dispensed.

Return the tape cartridge to the operation position.

Main Spring

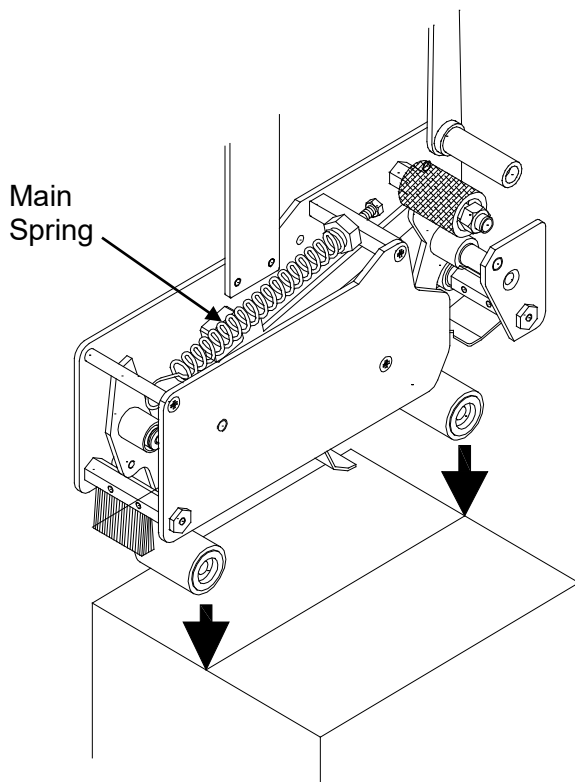

For sealing light weight boxes, decrease the main spring tension. For heavier boxes, increase the main spring tension.

When setting tension for the rollers, consider the amount of pressure on the box flaps required to make the seal. Cartons completely filled to the top with product may require more pressure on top and bottom seams when applying tape than partially-filled cartons, where excessive pressure could possibly crush the carton.

Control Panel

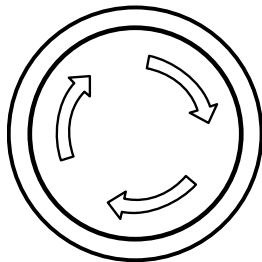
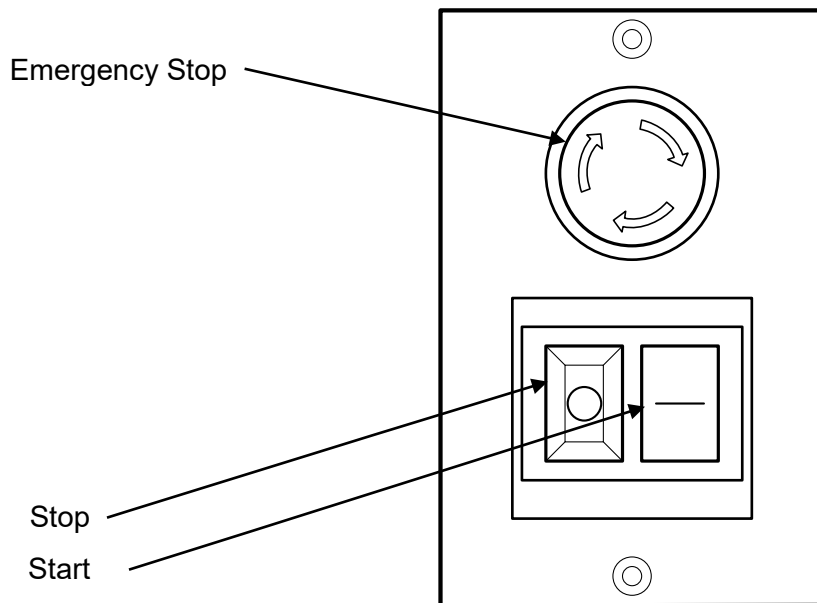

Emergency Stop Button

Press the button for emergency stop.

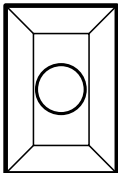

Stop

Press to stop motors and belts but keep power to the system on. (Non-emergency stop.)

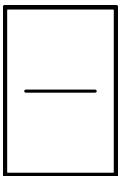

Start

Press to start motors and belts.

Start and stop buttons are covered by a clear plastic to protect them from dust, dirt, etc.

To reset the Emergency Stop button once the emergency condition has been cleared and it is safe to operate the machine again, press the Emergency Stop button in while turning it approximately a quarter-turn in the direction indicated by the arrows.

Adjustments

Box Width and Height Adjustment

Place a box filled with product on the in-feed table. Position the box centered with the conveyor drive belt and tape heads. Use the filled box to adjust the width of guide rails and top tape head height to accommodate the box width and height as explained in the instructions that follow. (If the case taper is equipped with optional top squeezers, use the filled box to adjust these too.)

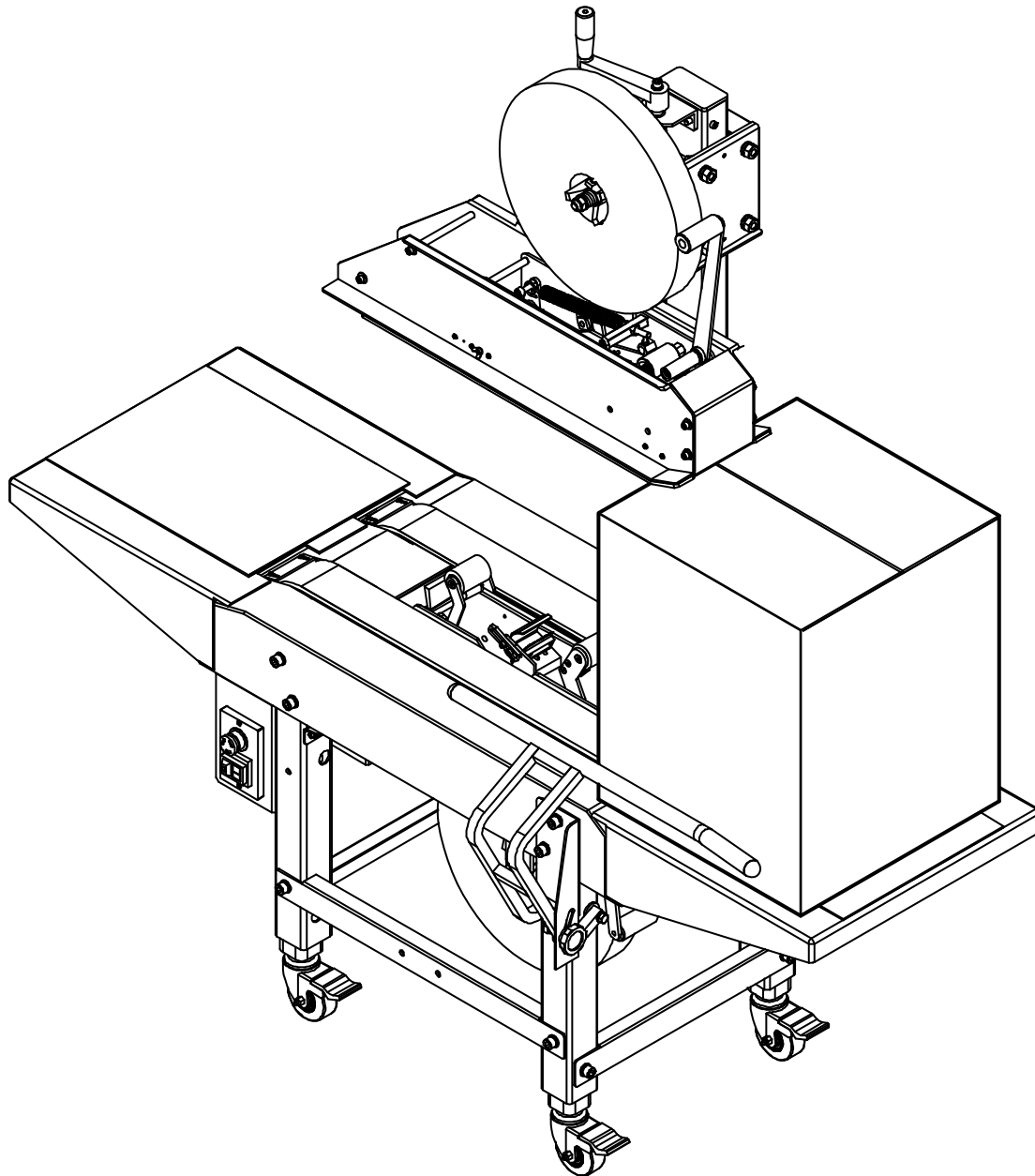

Guide Rail Adjustment

The purpose of the guide rails is to guide the box into the center of the machine as it is fed into the conveyor from the in-feed table. Keeping the box centered on the conveyor keeps the tape heads centered with the box, which keeps the tape seal on-center as it is applied to the box on the top or bottom seams.

To adjust the guide rail width, loosen the hand knob below the in-feed table on the leg on the side opposite the mast. Guide rails are mechanically linked so they will both rotate equal distance as they are adjusted. Move the guide rails to the width required for the box, and then retighten the hand knob with the guide rails in the new position.

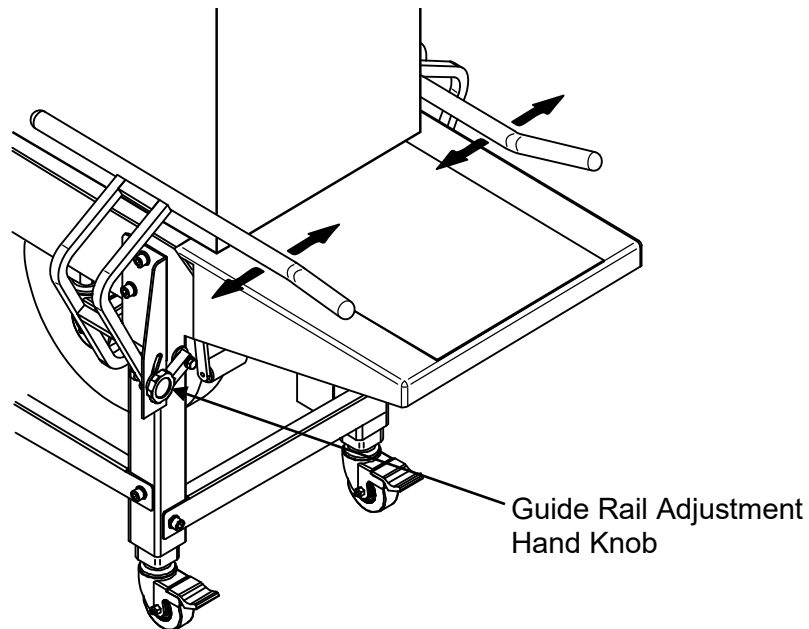

Top Tape Head Height Adjustment

Use the hand crank at the top of the mast to adjust the top tape head height to accommodate box height, as shown in the following illustration. Turn the crank counter-clockwise to raise the tape head. Turn the crank clockwise to lower the tape head.

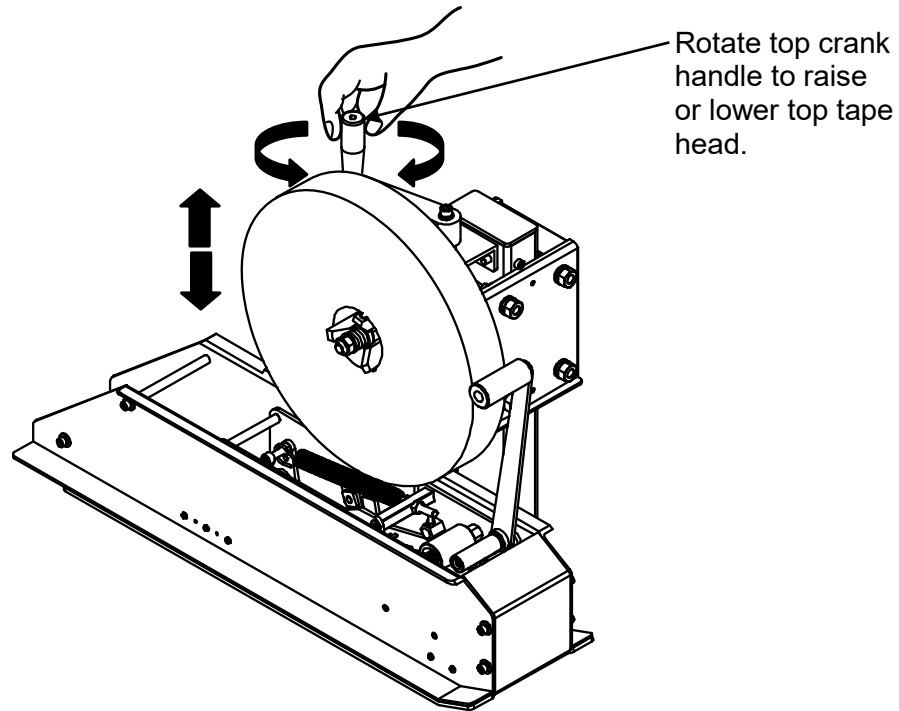

Top Squeezer Adjustment

(When equipped with optional top squeezers.)

If optional top squeezers are installed, adjust top squeezers to the box width, moving each box guide horizontally to the required width. Keep squeezer guides equal distance from the tape head center to keep the box centered on the conveyor and to keep the tape seal centered on the box seam.

Belt Adjustment

To adjust the belt tension, loosen the hex socket cap screws (A) in the slotted holes in the belt housing below the idler, then adjust the hex socket tensioning screws (B) in the end. When belt is set to the required tension, re-tighten the hex socket cap screws (A).

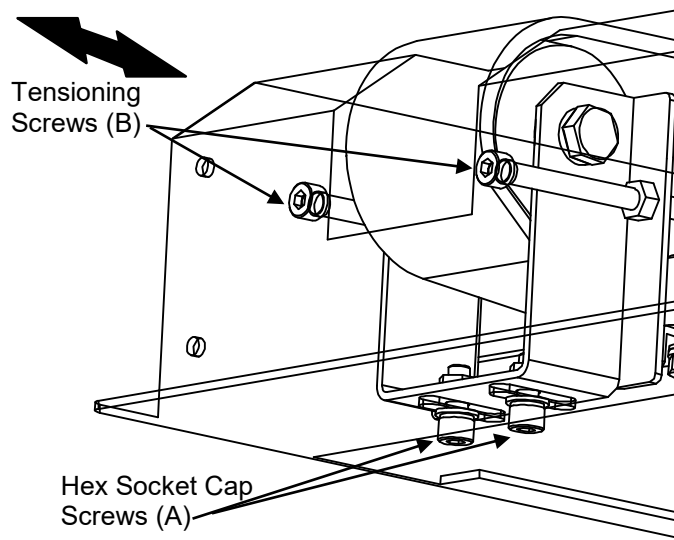

Tape Head Adjustment — Refer to Tape Head User Guide.

Refer to instructions in the Tape Head User Guide that is provided with the tape head for instructions regarding adjustment information for the tape head.

Maintenance

The BB-2/3T Case Taping System will provide many hours of maintenance free operation. There are a few items that may require attention from time to time.

Rollers

Make sure rollers stay clean and grease free. If you should have to clean the rollers simply wipe them down with a clean lint-free cloth. If a more thorough cleaning is necessary wipe the rollers down with a mild detergent and water and let dry. **Never use harsh or abrasive cleaners or chemical agents when cleaning the rollers.**

Cutting Knives

Occasionally inspect the cutting knives to ensure they are clean and free of adhesive residue. Make sure the cutting knife is sharp by inspecting cuts in the tape. Cuts should be straight and neat. If the quality of cuts is eroding, the knife blade is dull and should be replaced.

Changing Knife Blades — Refer to Tape Head User Guide

Turn off and unplug the taper. It is not necessary to remove either tape head to change the blade. Refer to the Tape Head User Guide provided with the tape head for instructions for changing the knife blades.

CAUTION! Always be aware of the cutting edges while replacing the knife blades. Handle the knife blades carefully.

Changing Drive Belts

Turn off and unplug the taper.

Loosen the tension on the belt completely.

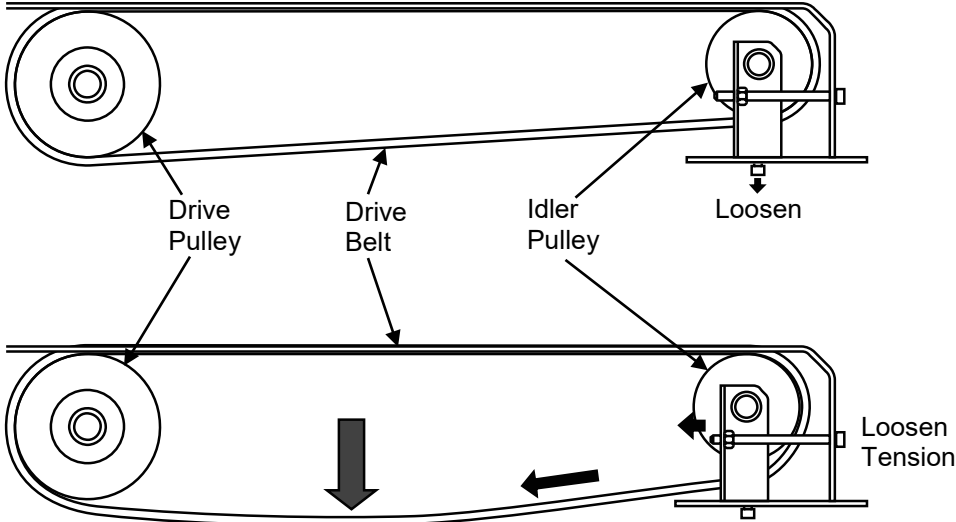

With the belt loose, remove the connecting pin that holds the belt together.

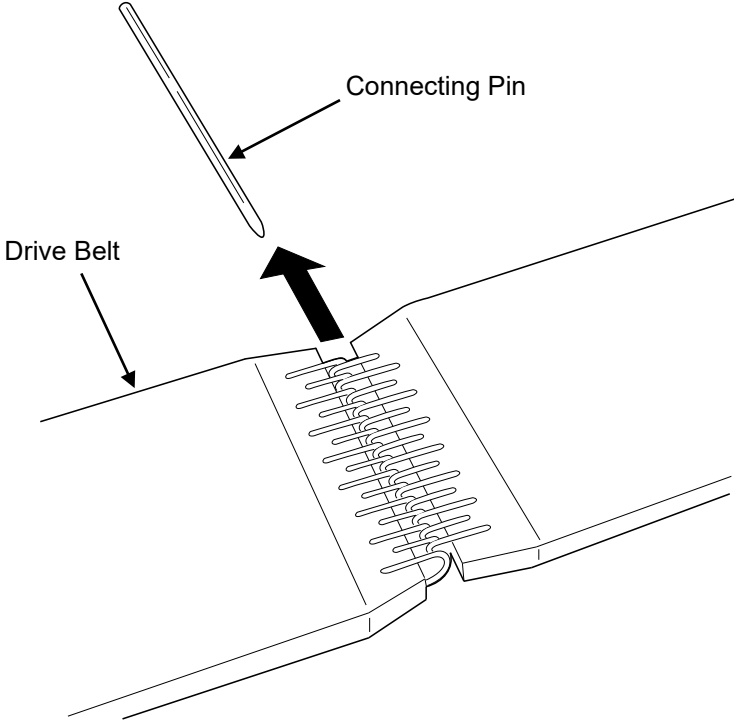

Take the belt off the machine.

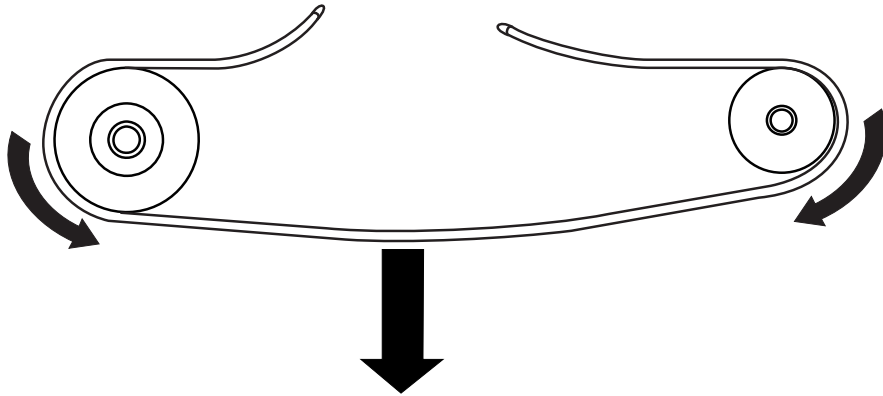

Install the new belt around the drive and idler pulleys.

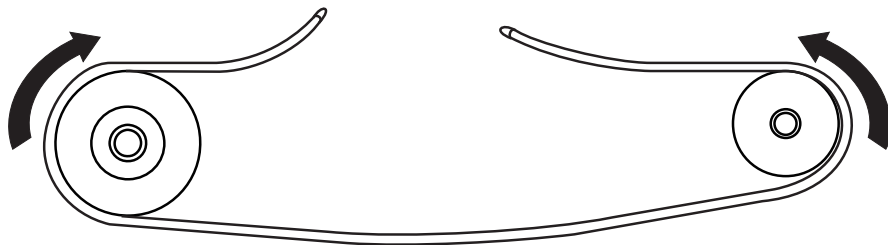

While the belt is still loose, connect the ends by lining up the loops and replacing the connecting pin.

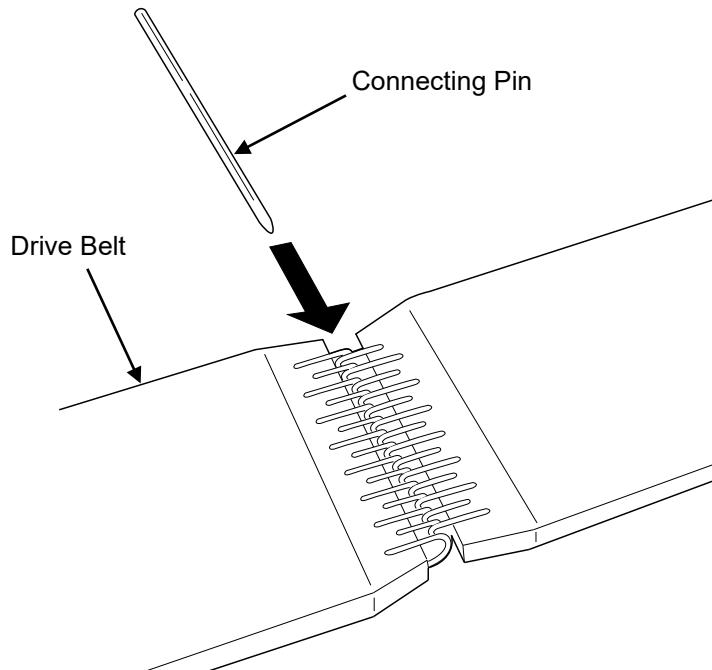

Using the tensioning bolts, restore tension on the idler pulley.

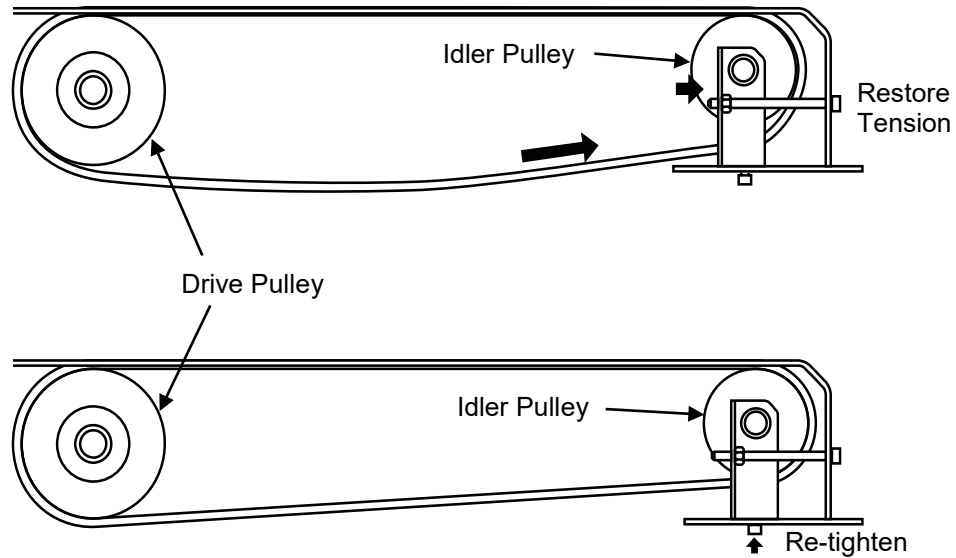

Retighten the socket head cap screws in the bottom of the conveyor to secure the idler pulley brackets in place.

Plug in and turn on the BB-2/3T Case Taper to resume taping.

Troubleshooting

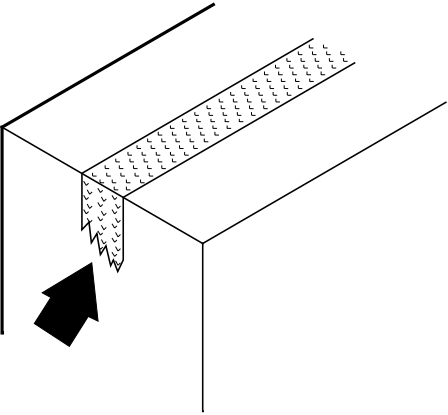
Problem	Solution
Machine is not operating	<ul style="list-style-type: none"> • Machine has inadequate electrical power or power is not connected. Verify system power meets specification requirements. • An Emergency Stop condition exists. Clear the machine and reset the Emergency Stop.
Machine cannot tape cartons	<ul style="list-style-type: none"> • The height or width adjustments are not set correctly for the box size. See Adjustments section to make adjustments for box size.
Uneven Tape Leg on Front	<ul style="list-style-type: none"> • Tape tension is too low. Tighten the one-way clutch roller and/or the tape core. • Adjust the one-way clutch roller in the slot so it is slightly beyond the front wipe roller. • Adjust the tape leg length. See Tape Leg Adjustment section.
Uneven Tape Leg Rear	<ul style="list-style-type: none"> • Too much tape tension. Adjust the one-way clutch and or tape core. • Clean and ensure all rollers move freely. Lubricate all roller slots. • Tighten main spring.
Uneven or Torn Tape 	<ul style="list-style-type: none"> • Blade is dull. Replace blade. • Tape tension is incorrect. Increase tension. • Clean and adjust blade. • Blade mounted incorrectly or backwards. • Knife arm spring is worn. Replace knife arm spring. • Adjust cartridge height.

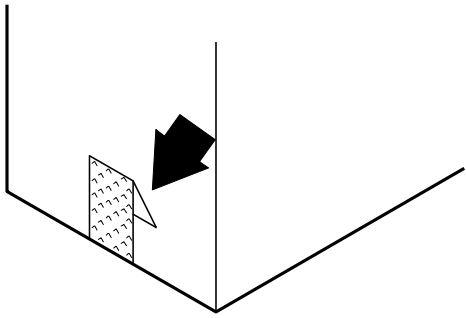
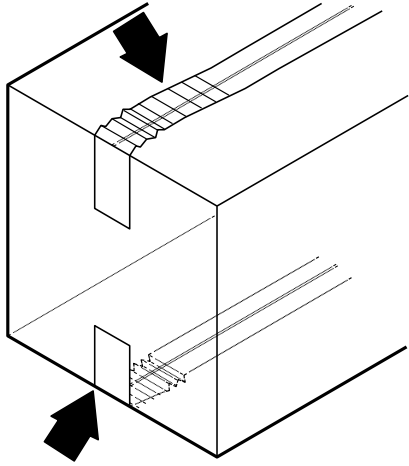
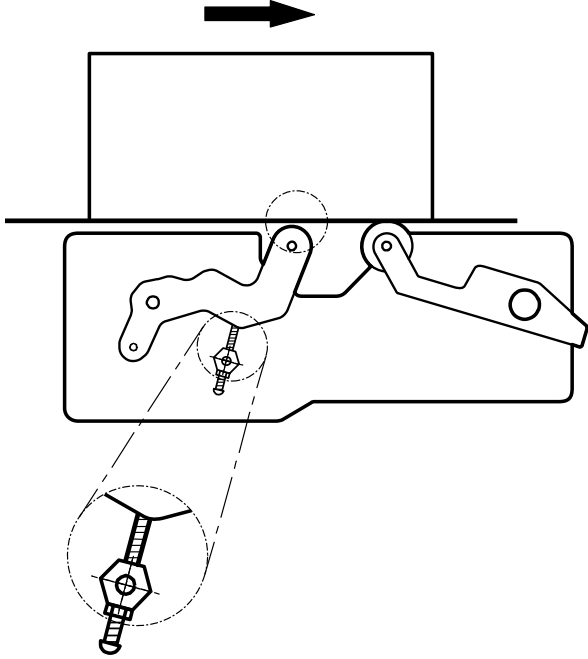
Problem	Solution
<p>Tape Folding</p> 	<ul style="list-style-type: none"> • Check that all rollers turn freely. • Check to be sure tape is threaded properly on front roller (page 17). • Check wipe down brush.
<p>Tape Curling and Bunching Up — Eastey-EX Tape Head Only</p> 	<p>Eastey-EX Tape Head Only</p> <ul style="list-style-type: none"> • Adjust the tape cartridge height (approximately .06 inches from box)  <ul style="list-style-type: none"> • Check tape tension set by the spring tension at the tape core.

Parts List

Electrical

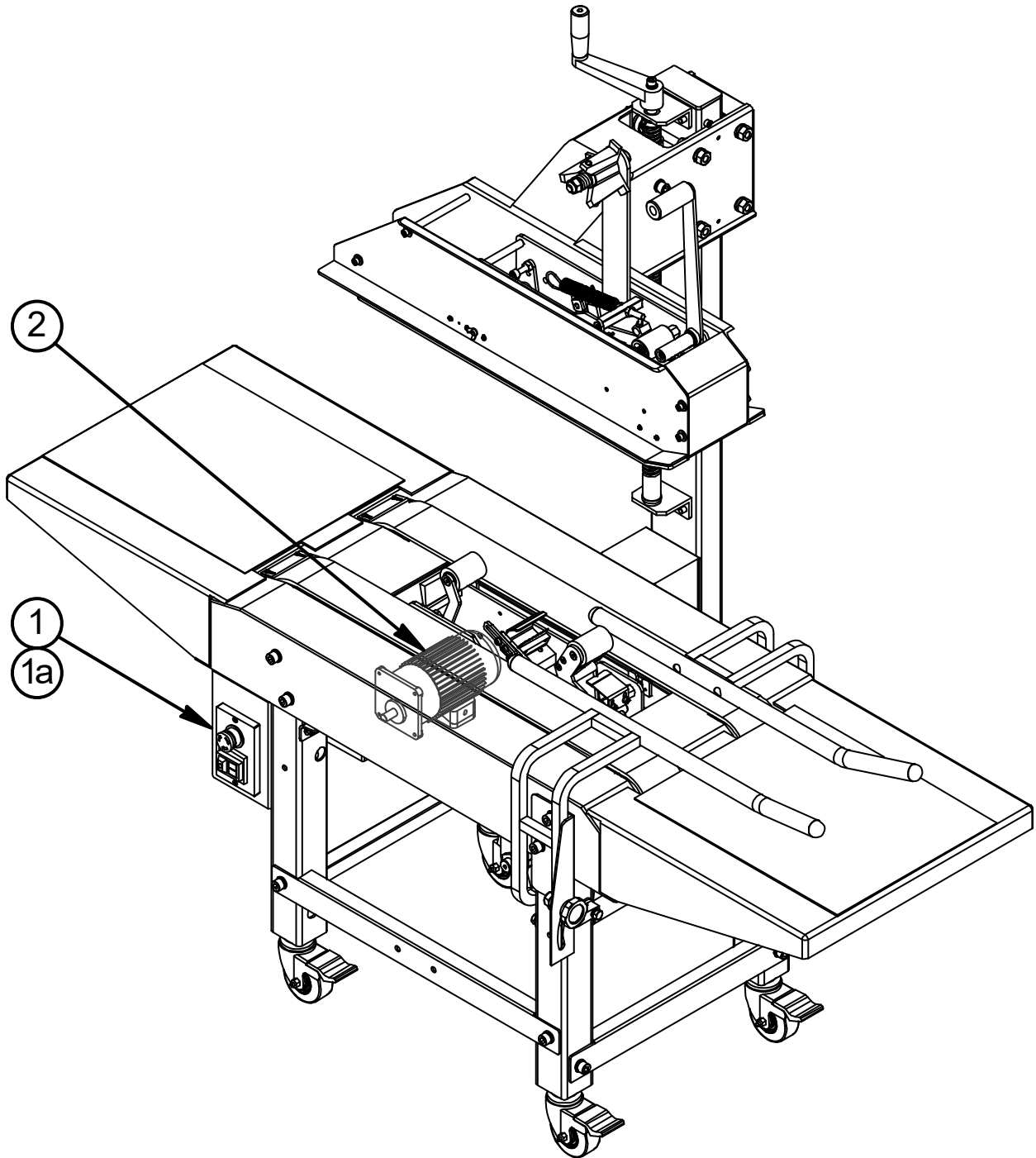

Electrical Layout

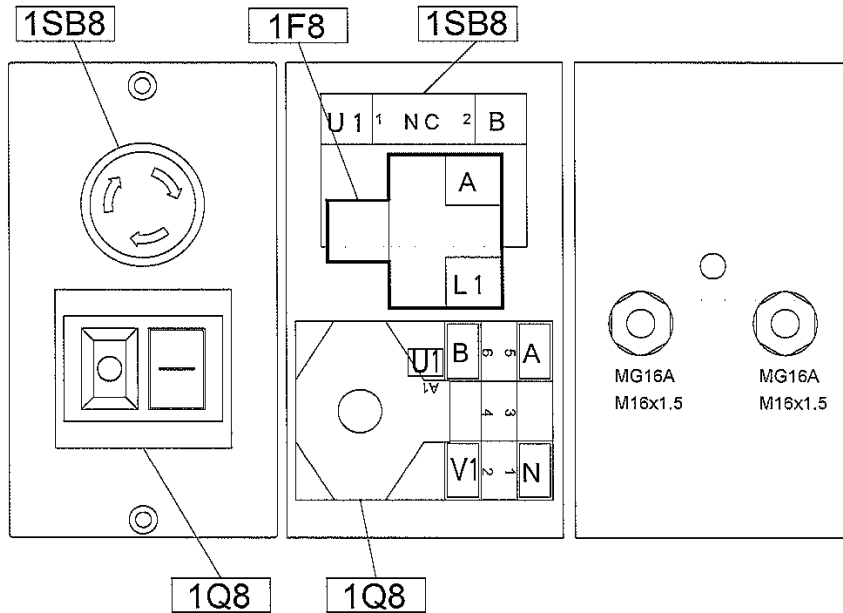

Motor Detail

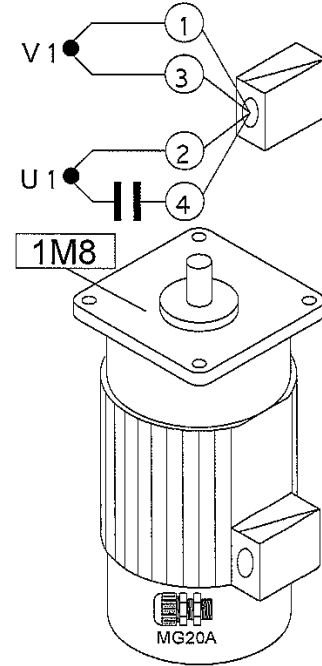

ITEM	DESIGNATOR	PART NUMBER	DESCRIPTION	OLD PART NO.	Q'TY.
1	1Q8	5001264-BBT-V1 5001264-BBT-V0	ELECTRICAL BOX, 230 V ELECTRICAL BOX 110 V	P0323-0000600 P0323-0000700	1
1a	1F8	5005197	FUSE	P0305-030002600	1
2	1M8	5001714-TB 5001714-BB-V1	MOTOR 110V/60Hz T18:1 MOTOR 110V/50Hz T15:1 MOTOR 210V/60Hz T18:1 MOTOR 210V/50Hz T15:1	745111M1 745111M2 745122M1 745122M2	1

Machine Body and Tables

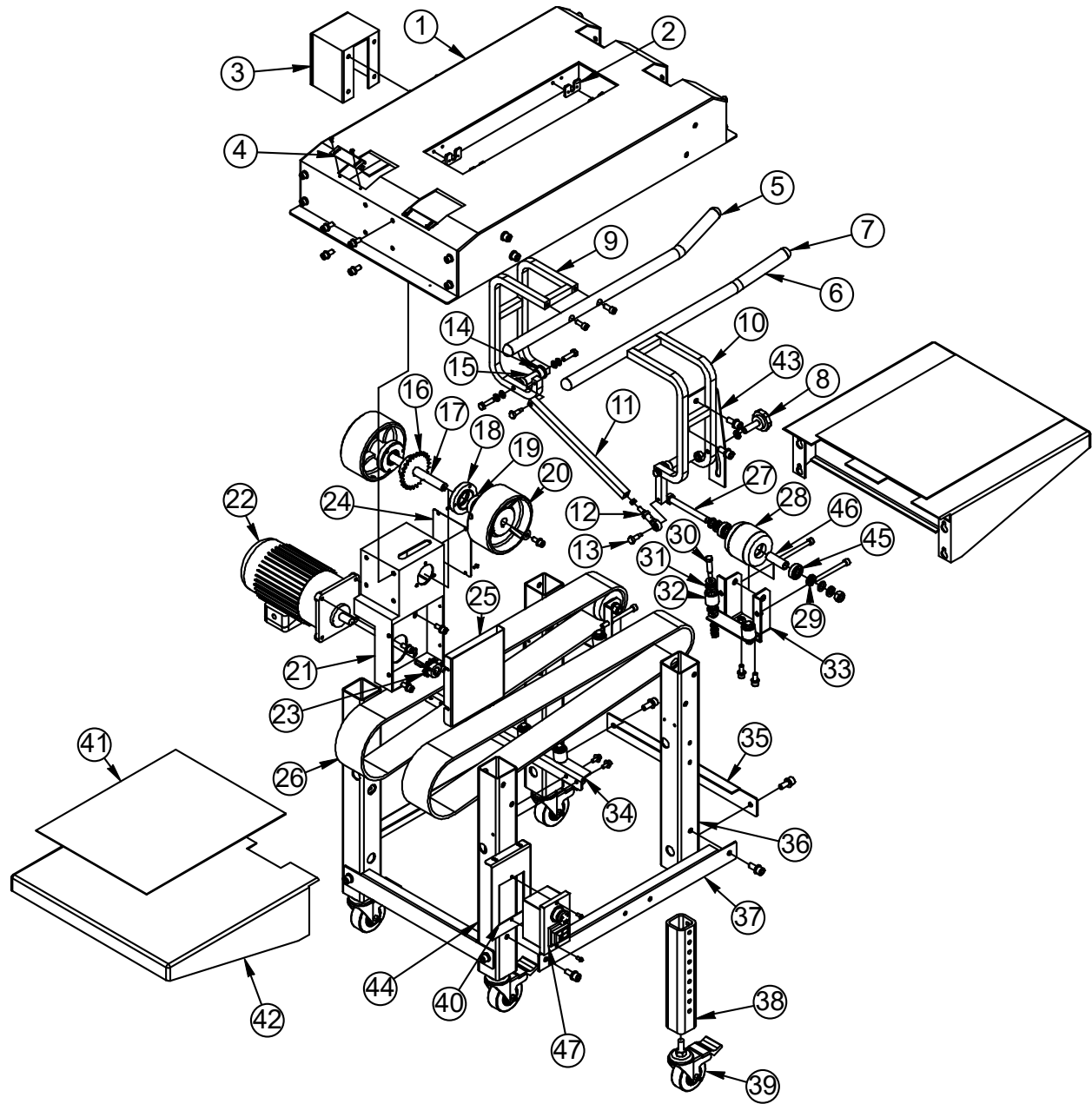

ITEM	PART NO.	DESCRIPTION	OLD PART NO.	Q'TY
1	5004137	MACHINE FRAME	KA11106710	1
2	5004132	PLATE A	CA33060A	4
3	5004138	CONNECTING BASE	KA11108000	1
4	5004139	SAFETY COVER	DA11107400	2
5	5002147	GUIDE RAIL (SQUEEZER) BAR (R)	KA030520R0	1
6	5002116	GUIDE RAIL (SQUEEZER) BAR (L)	KA030520L0	1
7	5004140	CAP PLUG	P1114-010001200	4
8	5002131	HANDLE KNOB M10 × 40I	KA0400610	1
9	5004141	GUIDE RAIL (SQUEEZER) ARM (R)	KA11107510	1
10	5004142	GUIDE RAIL (SQUEEZER) ARM (L)	KA11107610	1
11	5004143	GUIDE RAIL SIMULTANEOUS BAR	KA03051800	1
12	5002133	JOINT BEARING PHS08	81060051	1
13	5002132	SCREW	KA03052700 / 5001993	2
14	5004144	RING	KA30016100	4
15	5004145	GUIDE RAIL (SQUEEZER) ARM SHAFT	P02-016200A	2
16	5001922	CHAIN WHEEL	KA31005800	1
17	5001939	SHAFT	KA03066400	1
18	5001867	BEARING SEAT	CA131000	2
19	5001701	BEARING 6203ZZ (CWB)	30302030	2
20	5002102	BELT ROLLER	P0703-000670B	2
21	5004146	MOTOR SPROCKET WHEEL	KA11117000	1
22	5001714-TB 5001714-BB-V1	MOTOR 110V/60Hz T18:1 MOTOR 110V/50Hz T15:1 MOTOR 210V/60Hz T18:1 MOTOR 210V/50Hz T15:1	745111M1 745111M2 745122M1 745122M2	1
23	5001905	CHAIN WHEEL 12T	CA331300	1
24	5004147	CHAIN COVER	KA11118600	1
25	5004148	MOTOR COVER	KA11117200	1
26	5001040	BELT	KA30016800	2
27	5004149	BELT ROLLER SHAFT	KA03052300	2
28	5000969	BELT ROLLER	KA30016500	2
29	5002151	BELT WASHER	KA30019000	4
30	5004150	ROLLER SHAFT	KA03055600	4
31	4500171	BEARING 6900ZZ	30309000	8

34 Illustrated Parts List

ITEM	PART NO.	DESCRIPTION	OLD PART NO.	Q'TY
32	5004151	ROLLER	KA30016700	4
33	5004152	BELT ROLLER SUPPORT	KA11108400	2
34	5004153	CASTER FIXER	P01-022400A	1
35	5004154	FIXED PLATE	KA11107800	2
36	5004155	LEG	P01-020000C	2
37	5004156	FIXED PLATE	KA11107900	2
38	5002107	ADJUSTABLE LEG	KA11107700	4
39	5001902	CASTER, SWIVEL, LOCKING	KA04010800	4
40	5004157	CONTROL BOX FIX PLATE	KA11113600	1
41	5002117	PACKING PLATE	KA30016600	2
42	5004158	PACKING TABLE	KA11106810	2
43	5004159	GUIDE RAIL GUIDE	KA11108500	1
44	5004160	LEG	P01-020100C	2
45	5000968	BEARING 6201ZZ	30302010	4
46	5004161	RING	KA03076600	2
47	5001264-BBT	ELECTRICAL BOX 110V	KA02002810 / P0323-0000700	1
	5001264-BBT-V1	ELECTRICAL BOX 230V	KA02002800 / P0323-0000600	1

Mast and Upper Tape Head Seat

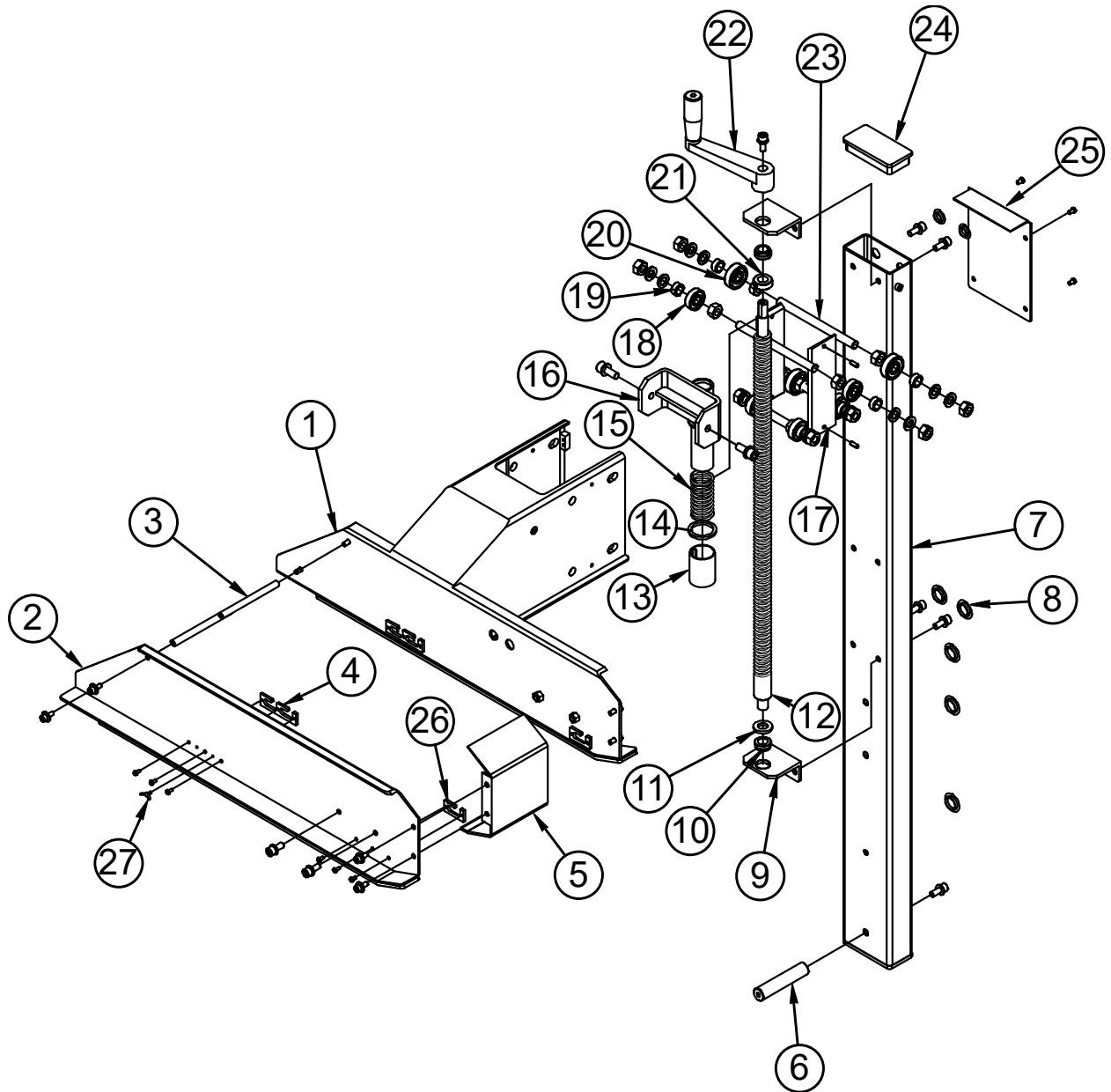

ITEM	PART NO.	DESCRIPTION	OLD PART NO.	Q'TY
1	5004162	UPPER TAPER SEAT	KA11106910	1
2	5004163	UPPER TAPER FRONT PLATE	KA11107010	1
3	5004164	PLATE HOLDING SHAFT	KA03051210	2
4	5001696B	UPPER BLOCK B	CA100300	2
5	5004165	UPPER TAPER SHIELD	KA11108110	1
6	5004166	PLATE HOLDING SHAFT	KA03051100	3
7	5004167	COLUMN	KA11107300	1
8	5004168	PLUG - HP25	7030HP25	5
9	5004169	FIXED PLATE	KA11129800	2
10	5004083	RING	CA200200-01	2
11	5004084	WASHER AS1528	3036AS05	2
	5004085	BEARING AXK1528	30301528	1
12	5004086	HEIGHT ADJUSTABLE SPINDLE	KA03072800	1
13	5004087	NUT, LEADSCREW	CA1-1061-01	1
14	5004088	WASHER	KA11129700	1
15	5004089	SPRING	KA04014500	1
16	5004090	SPINDLE SEAT	KA03072900	1
17	5004170	COVER PLATE	KA30016300	2
18	5000968	BEARING 6201ZZ	30302010	4
19	5004171	RING	KA03051300	8
20	5004172	BEARING 6301ZZ	30303010	4
21	5004176	FIXED RING	KA03009600	1
22	5001710	HANDLE CRANK ARM	CA201500	1
23	5004091	BEARING SEAT	KA03052400	4
24	5004174	SQUARE PLUG	91350007	1
25	5004175	COVER	KA11108300	1
26	5001697B	UPPER BLOCK A	CA100200	2
27	5001913	SCREW-WING THUMB M4 × 10		

Tape Head (2" or 3") — Refer to Tape Head User Guide.

Refer to the User Guide provided with the Tape Head for the Illustrated Parts List and part numbers for Tape Head parts.

Appendix A: Electrical Schematic

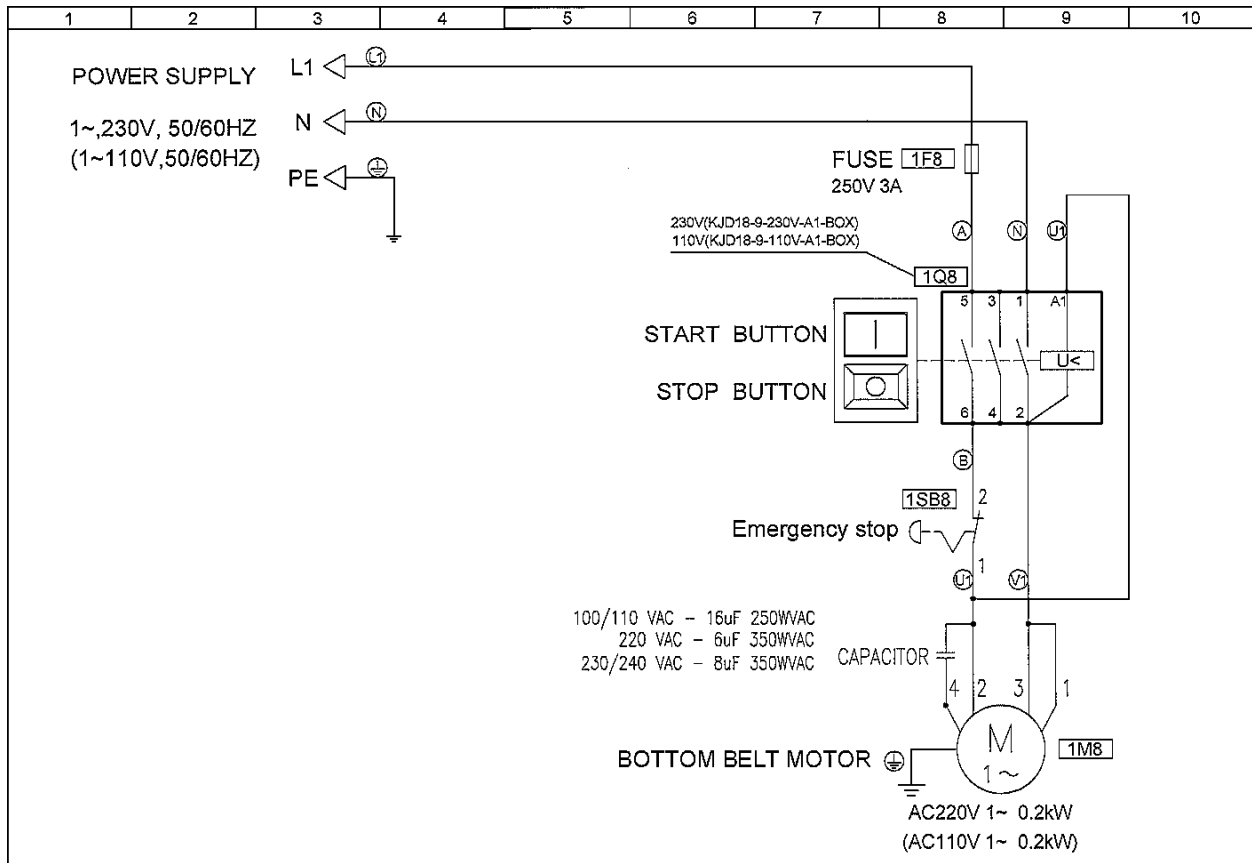

Warranty Statement

BB-2/3T Case Taping System

Warranty Statement

Eastey warrants that all of the products it ships will be in good working order and free from defects in material and workmanship and will conform to the published specifications for that product.

Warranty Period

Drive motor(s): 1 year

Tape head: 1 year (Except for moving parts which are subject to normal wear, tear and replacement which are warranted to be free from defects in material and workmanship.)

All other parts: 1 year (Except for moving parts which are subject to normal wear, tear and replacement which are warranted to be free from defects in material and workmanship.)

Taping Quality

Taping quality achieved in a given application is dependent on the installation, the material handling, and the maintenance provided. Eastey makes no warranty that the taping quality achieved in an application will be the same as that achieved on a test piece in our demo facility.

Shipping Policy

Customer pays all incoming shipping. If the item is defective and under warranty, Eastey pays return shipping charges for least costly method. If expedited shipping is desired, customer must furnish his shipping account and shipping fees will be charged to that account.

Warranty Verification

If you conclude that a product may be defective and may be covered by warranty, obtain a Return Material Authorization number by calling our technical support number (toll free at 1-800-835-9344, or 763-428-4846 or Fax: 763-795-8867) or e-mail: info@eastey.com. Once an RMA number has been obtained, return the defective item to Eastey. Eastey will analyze the product and, if found to be defective, we will, at our option, replace or repair the item. If the item is found to not be eligible for warranty, you will be notified and may decide on disposition. Defective products will be replaced or repaired as soon as possible.

Warranty Eligibility

The warranty provided by Eastey is only to the original buyer.

Limited Warranty

THE ABOVE WARRANTY IS EXCLUSIVE AND IN LIEU OF ALL OTHER WARRANTIES, WHETHER EXPRESSED OR IMPLIED, INCLUDING THE IMPLIED WARRANTIES OF MERCHANTABILITY, FITNESS FOR A PARTICULAR PURPOSE AND NONINFRINGEMENT.

Disclaimer of Damages

REGARDLESS OF WHETHER ANY REMEDY SET FORTH HEREIN FAILS OF ITS ESSENTIAL PURPOSE, IN NO EVENT WILL EASTEY BE LIABLE FOR ANY SPECIAL, CONSEQUENTIAL, INDIRECT OR SIMILAR DAMAGES, INCLUDING LOST PROFIT OR LOST OPPORTUNITIES OF ANY TYPE ARISING OUT OF THE USE OR INABILITY TO USE THESE PRODUCTS EVEN IF EASTEY HAS BEEN ADVISED OF THE POSSIBILITY OF SUCH DAMAGES.

Customer Support

Eastey Technical Service

For help setting up or operating the BB-2/3T Case Taper, please contact Eastey Technical Service at one of the numbers listed below.

Toll-Free Phone 800-835-9344
Phone 763-428-4846
Fax 763-795-8867
E-mail info@eastey.com
Web www.eastey.com

Thanks again for your purchase of Eastey products. We are pleased to be a part of your packaging needs.



EASTEY®