

# ETB

ETB3012 & ETB3020

---

## Bundling Tunnels Performance Series

# User Guide

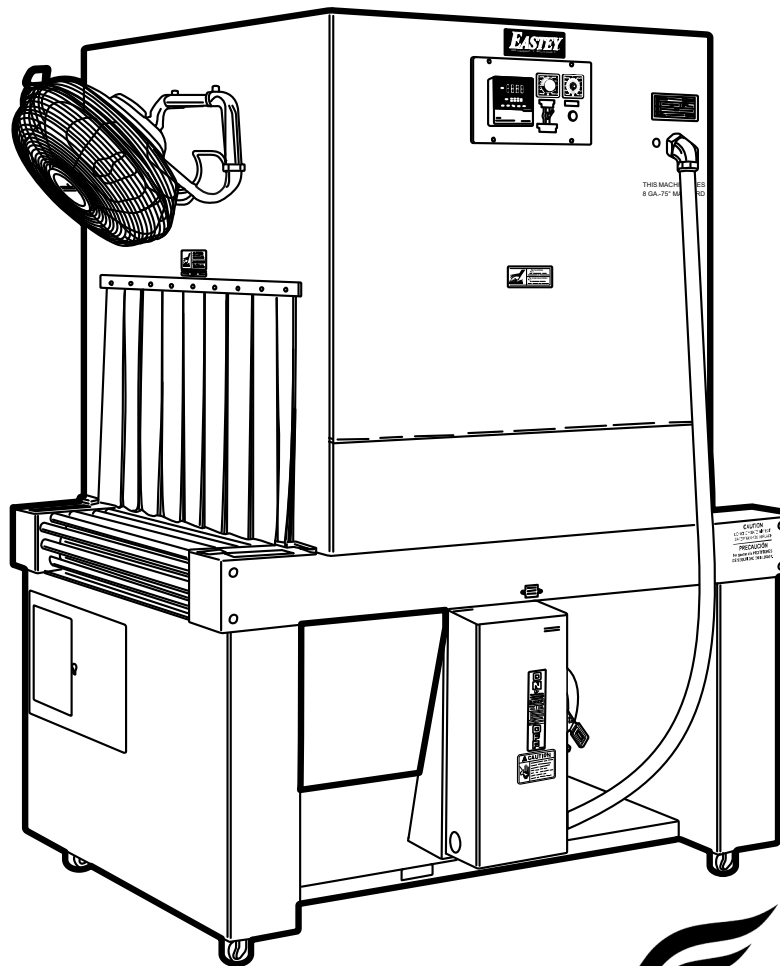

---

**EASTEY**<sup>®</sup>



# ET

# ETB3012 & ETB3020

# Bundling Tunnels Performance Series

# User Guide

Revised 12/13/2019

P/N ETB00900 Rev A

## **Copyright and Trademarks**

Copyright ©2019 Engage Technologies Corporation  
All rights reserved. All trademarks and brand names  
are the property of their respective owners.

Eastey  
7041 Boone Ave. N.  
Brooklyn Park, MN 55428

Phone: (763) 428-4846; Fax (763) 795-8867; 1-800-835-9344

**[www.eastey.com](http://www.eastey.com)**



# Contents

- Safety ..... 7**
  - Explanation of Symbols..... 9
  
- Introduction ..... 10**
  - ETB3012 & ETB3020 Bundling Tunnel Overview ..... 10
  - Specifications ..... 11
  - Dimensions ..... 13
  
- Unpacking..... 14**
  - Loading and Unloading Instructions ..... 14
  
- Installation ..... 15**
  - Location Requirements ..... 16
  
- Operation ..... 18**
  - Main Power Disconnect ..... 18
  - Control Panel ..... 18
  - Sequence of Operation ..... 19
  
- Adjustments ..... 21**
  - Temperature Controller Settings (ETC00011) ..... 21
  - To Change the Set Value..... 22
  
- Maintenance ..... 24**
  - Preventative Maintenance..... 24
  - Preventative Maintenance for Modular Plastic Conveyor Belts ..... 25
  - Conveyor Belt Tension Adjustment..... 26
  - Replacing Conveyor Components..... 26
  - Replacing Tunnel Components ..... 28
  - Belt Assembly and Disassembly ..... 30
  
- Troubleshooting..... 33**
  
- Parts List..... 38**
  - ETB3012-V2 & ETB3020-V2 220VAC 50 Amp 3 Phase..... 38
  - Spare Parts List..... 38
  
- Appendix A: Electrical Schematic ..... 39**
  - Electrical Schematic ETB3012-V2 & ETB3020-V2..... 39
  - 220VAC 50 Amp 3 Phase..... 39
  - Electrical Schematic ETB3012-V2 & ETB3020-V2..... 40
  - 480VAC 25 Amp 3 Phase..... 40
  
- Warranty Statement ..... 42**
  
- Customer Support..... 44**



# Safety

Read this manual carefully and make it available to everyone connected with the supervision, maintenance, or operation of this machine. Additional copies are available on request ([Eastey.com/contact-us](http://Eastey.com/contact-us)).

The development of a good safety program that is rigidly enforced is absolutely imperative when involved in the operation of industrial equipment. Our machinery is well designed and includes extremely important safety features. The part you, the user, play through proper installation and maintenance procedures is of far greater importance than our design. Only properly trained individuals following rigidly enforced safety rules, as recommended by applicable national and local safety code organizations should be allowed to operate these machines.

Be very careful when operating, adjusting, or servicing this equipment. If in doubt, stop and obtain qualified help before proceeding.

## General Safety Precautions

Before installing, operating or servicing this equipment, please read the following precautions carefully:

- Always disconnect electrical power before attempting maintenance for any electrical or moving parts. Do not place hands, head, or any part of the body inside the confines of the machine unless the mechanism is securely fastened and the electrical supply is shut off.
- Do not tamper with electrical wiring. Use only the specified power-supply cable. Use only licensed electricians to check or repair electrical wiring.
- Do not by-pass any factory-designed safety features such as guards, interlocks, switches, etc.
- In order to prevent damage to the machinery or injury to personnel, do not increase the factory settings on either the electrical or mechanical overload safety devices. Do not operate a machine if such modifications have been made.
- Keep hands away from moving conveyors and moving parts. Conveyor belts that have become worn or frayed can be hazardous and should be replaced promptly.
- Never operate this or any moving equipment without all covers and guards in place. The internal mechanism of most packaging machinery contains numerous shear, pinch, and in-running nip point, many of which are capable of causing severe injury and permanent disfiguration.

- To minimize the potential for personal injury, always be sure that the machine operators and others working on the machinery are properly trained in the correct usage of the equipment and properly instructed regarding the safety procedures for operation.
- Tunnel sides and conveyor surfaces can become very hot after a period of use. Keep hands away while in operation and use caution if the machine has been running recently.
- Do not make any modifications to either the electrical circuitry or the mechanical assemblies of this machinery. Such modifications may introduce hazards that would not otherwise be associated with this machinery. Eastey Corporation will not be responsible for any consequences resulting from such unauthorized modification. Do not operate a machine if any modification has been made
- This equipment is designed for indoor operation in a typical clean, dry factory environment. Do not operate the machine in any extremely wet or oily environment that may exceed operating specifications. Outdoor use is not recommended.
- The use of certain types of plastic films in sealing and/or shrink-wrapping equipment may result in the release of hazardous fumes due to degradation of the film at high temperatures. Before using any plastic film in this equipment, the manufacturer or supplier of the film should be contacted for specific information concerning the potential release of hazardous fumes. Adequate ventilation should be provided at all times.
- Keep combustible materials away from this equipment. The equipment may be a source of ignition.
- Do not wear loose clothing such as ties, scarves, jewelry, etc. Long hair should be pulled back and/or covered while operating this machine.



## Explanation of Symbols



Caution sign or Safety Alert symbol. Indicates caution, be alert, Your safety is involved. Knowledge of safe operation is required.



Ground symbol. Indicates ground. Use Class-3 (lower than 1000) cable to ground to earth. Incomplete grounding may lead to electrical shock.



Electrical hazard. Indicates electrical danger. Only a trained electrician can uncover the electrical panel or box.



Electrical shock hazard. Indicates electrical shock danger from exposed or broken wires or electrical components. Only a trained electrician can uncover the electrical panel or box.



Burn hazard. Indicates a hot surface. Do not place your hand on or touch the hot surface, as doing so could result in burns. Shut down the machine and allow the surface to cool before touching surface.



Pinch hazard. Do not place your hands or any object on the moving mechanism. Shut down the machine before performing maintenance.



Moisture hazard. Keep equipment dry. This equipment is designed for indoor operation in a typical clean, dry factory environment, protected from rain and moisture. Do not operate the machine in any extremely wet or oily environment that may exceed operating specifications.

	<b>⚠ CAUTION</b> KEEP HANDS CLEAR MOVING PARTS CAN CRUSH AND CUT
	<b>⚠ ¡PRECAUCIÓN!</b> precaución mantenga sus manos alejandas partes móviles pueden aplastar y cortar

**THIS MACHINE REQUIRES  
8 GA. - 75° MAIN POWER CORD**

	<b>⚠ CAUTION</b> HOT SURFACES WHEN EQUIPMENT IS OPERATING
	<b>⚠ ¡PRECAUCIÓN!</b> LAS SUPERFICES CALIENTES CUANDO EL EQUIPO ESTÁ FUNCIONANDO
<b>CAUTION • PRECAUCIÓN</b>	
KEEP COMBUSTIBLE MATERIALS AWAY FROM THIS EQUIPMENT. THE EQUIPMENT MAY BE A SOURCE OF IGNITION MANTENGA ALEJADO DE MATERIALES COMBUSTIBLES ESTE EQUIPO EL-equipu puede ser una fuente de ignición	

# Introduction

## ETB3012 & ETB3020 Bundling Tunnel Overview

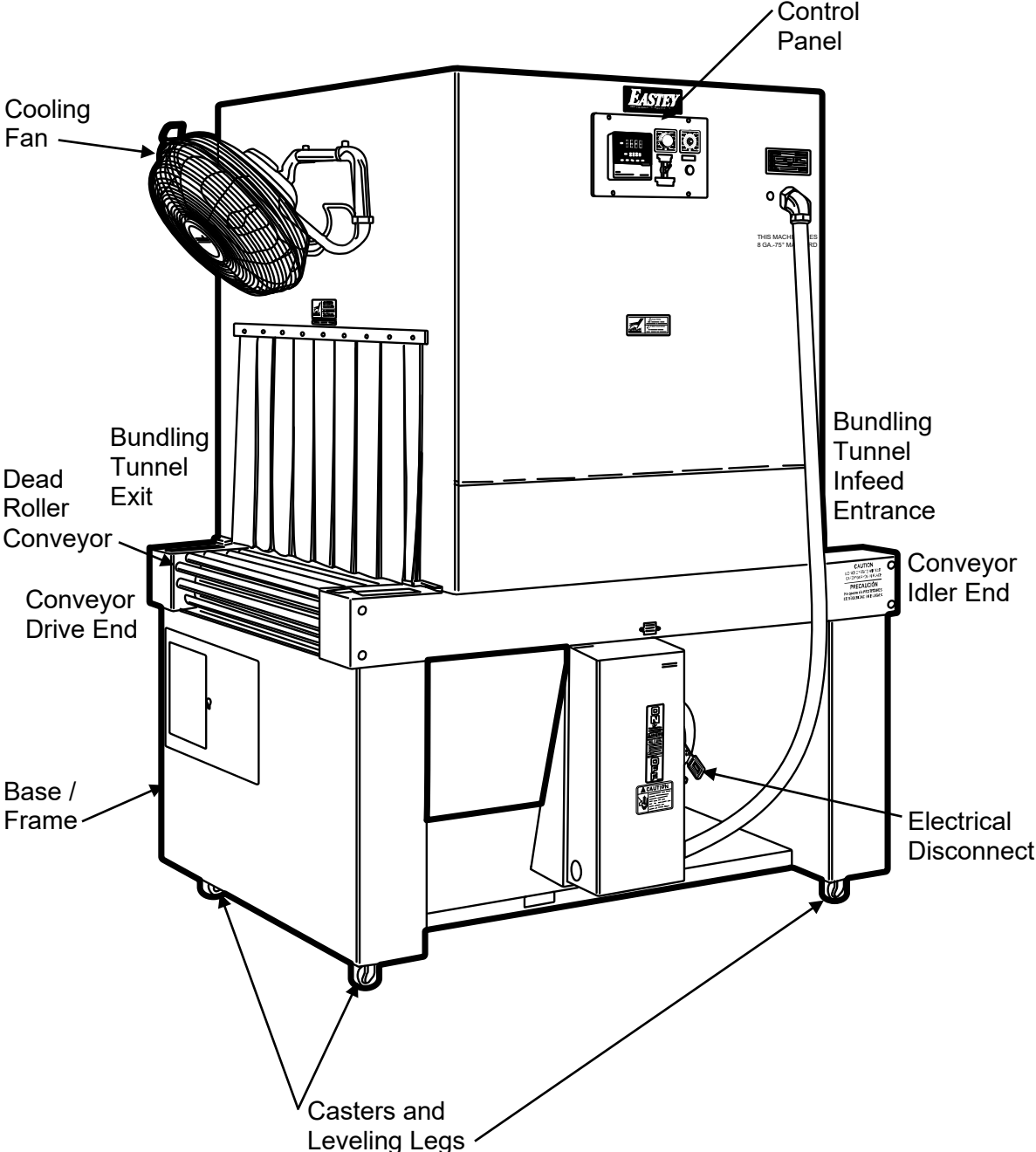

## Specifications

**Table 1 Machine Dimensions**

Model Number	Machine Dimensions			Chamber Dimensions			Conveyor		Floor	Shipping
	Width (A)	Height (B)	Length (C)	Width	Height	Length	Width Nominal	Length Overall	Weight	Weight
ETB3012	45 in. 114 cm	67 in. 170 cm	59 in. 149 cm	30 in. 76 cm	12 in. 30 cm	39 in. 99 cm	30 in. 76 cm	59 in. 149 cm	1200 lbs. 544 kg	1300 lbs. 589 kg
ETB3020	45 in. 114 cm	75 in. 190 cm	59 in. 149 cm	30 in. 76 cm	20 in. 50 cm	39 in. 99 cm	30 in. 76 cm	59 in. 149 cm	1250 lbs. 566 kg	1350 lbs. 612 kg

**Table 2 Standard Power Requirements**

Voltage / Phase Designator	Standard Power		
	Volts	Amperes	Phase
V2	220	50	3
V6	480	25	3

### Explanation of Model Numbers

- E = Manufactured by Easteey, packaging group division of Engage Technologies.
- T = Tunnel
- B = Bundler
- \_\_ = 30 — First two digits indicate the nominal width of the chamber opening and conveyor belt in inches: Nominal width of the conveyor belt and chamber opening is 30 inches.
- \_\_ = 12 or 20 — The next two digits (preceding the dash) indicate the nominal height of the chamber opening in inches: 12 or 20-inch chamber opening heights are available.
- V2 or V6 = Voltage and Phase, 220V 50A single-phase or 220V 25A three-phase are available.

### Example:

- Model number ETB3020-V2-nnnn: ETB indicates that the model is an Easteey Shrink Tunnel Bundler. 3020 indicates the chamber width is 30 inches (chamber and conveyor width are approximately the same) and chamber height is 20 inches. (Conveyor length and machine length will be 20 inches longer than the chamber length, figure twelve inches before the infeed/entrance and eight inches

past the exit.) V2 indicates 220 volts, 50 amperes and three-phase input. If SP appears in the model number suffix, this indicates it is a custom model (special project) and the numbers following SP (final numbers of the model number) indicate the project number.

### **Standard Features**

- Designed to shrink-seal polyethylene films
- All-welded main frame from 12-gauge steel
- 39-inch chamber length to ensure proper shrinking of film
- Dead roller conveyor for polyethylene
- Sealed bearings (not bushings) on drive and idler shafts
- Adjustable solid-state temperature control for a variety of films
- Four-directional air-flow provides positive shrinking
- Variable air-flow and air velocity for a variety of products and applications
- Large ducting creates more air volume inside tunnel
- Optional side plates (top and sides) for air flow patterning and quick changeover for different products
- Delayed cool down and over-temperature protection
- Heavy duty casters for transportation within plant
- Leveling legs provide sturdy base once in place
- Custom two-part epoxy finish resists scratching
- Available in 220V single-phase or three-phase power input
- Easy to use design requires minimal training and maintenance, and provides trouble-free operation
- Made in the USA

### **Optional**

- Plastic conveyor belt.

# Dimensions

All dimensions are shown in inches. See A, B, and C dimensions in Specifications table for overall machine length, height, and width.

## Model ETB3012

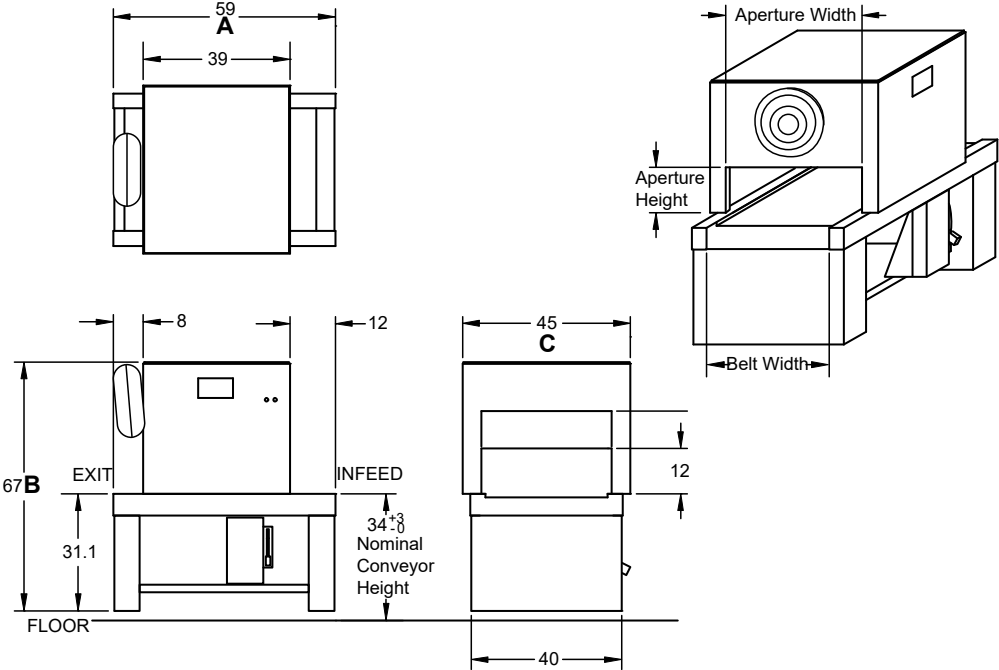

## Model ETB3020

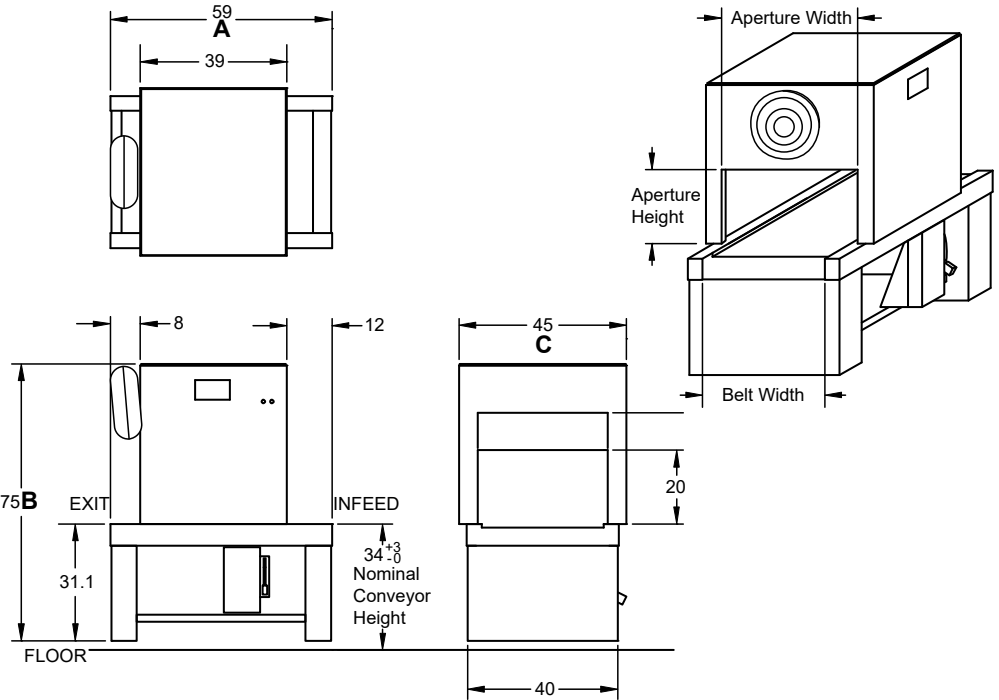

# Unpacking

Thoroughly inspect the equipment and packaging immediately on arrival.

Carefully remove the outer protective shipping materials. Inspect the machine for any damage that may have occurred during transit. If goods are received short or in damaged condition, it is important that you notify the carrier's driver before they leave your company and **insist** on a notation of the loss or damage across the bill of lading. Otherwise no claim can be enforced against the transportation company. Please note that a copy of this document is attached to the outside of every crate.

If concealed loss or damage is discovered, **notify your carrier at once** and request, **insist**, on an inspection. This is absolutely necessary. A concealed damage report must be made within **ten (10)** days of delivery of shipment.

Unless you do this, the carrier will not entertain any claim for loss or damage. The agent will make an inspection and grant a concealed damage notation. If you give the transportation company a clear receipt for the goods that have been damaged or lost in transit, you do so at your own risk and expense.

We are willing to assist you in every reasonable manner to help you collect claims for loss or damage. However, this willingness on Eastey's part does not make Eastey or its parent or related companies responsible for collections or claims or replacement of equipment damaged or lost in transit.

## Loading and Unloading Instructions

- The machine is fully crated on pallets.
- A forklift with long forks is required for unloading.
- A loading dock must be available at the facility where the Bundling Tunnel is to be unloaded.

# Installation

Carefully unpack the outer carton and shipping material. Although the exterior of the bundling tunnel is coated with a custom two-part epoxy finish that resists scratching, avoid denting, scratching, or otherwise damaging the oven exterior.

Lift the machine up and off of the shipping pallet.

**CAUTION! ET Performance Series Bundling Tunnels are heavy and may require a forklift, floor crane, or several people to move the machine safely. Use proper equipment when lifting the bundling tunnel and ensure it is secure and will not shift while being moved off the shipping pallet.**

Place the bundling tunnel in the desired location with the required electrical power source available. (See power requirements for the specific model in the Specifications table.) Make sure the electrical wiring is adequate to provide the required voltage. If the voltage provided is too low, the equipment will not operate correctly.

Selecting the proper location is one of the most important considerations for initial setup. When selecting the location, take into consideration the following factors.

1. Adequate power supply nearby?
2. Where is the bundling tunnel in relation to the power source?
3. Where is the bundling tunnel in relation to the sealer and any conveyor(s) necessary to move wrapped and bundled (finished) product? (Alignment with packaging line.)
4. Convenience for the operator.

**Note: Avoid locating the bundling tunnel in cold or drafty areas, as heat may be unintentionally drawn from the tunnel and reduce its efficiency.**

If there is any doubt, get qualified assistance with your initial installation.

## Location Requirements

When installing the bundling tunnel please be aware of the following considerations:

1. The surface on which it is located is flat and level.
2. Conveyor or packing table height.
3. Alignment with packaging line.

When the bundling tunnel is positioned in the operating location you will need access to the control panel.

Provision should be made for finished exiting packages. For example, a table or bin where packages that have been sealed will be placed until they can be picked up or moved out.

Take into consideration the entrance conveyor height in relation adjacent machinery, such as the sealer feeding into it, for example.

The machine should be placed on a flat, level floor so that it does not rock or move. We recommend that the leveling feet be used to level the machine.

Set up the bundling tunnel and move it to its location. The casters allow easy movement over smooth flat surfaces.

**CAUTION! If the bundling tunnel must be lifted for moving, use proper equipment when lifting and moving it to ensure it is secure and will not shift.**

When the bundling tunnel has been moved to its location, use the leveling legs to level the conveyor and adjust it to its final height. A power cord to the main electrical disconnect switch (with optional electrical plug) should be installed by a licensed electrician.

**Note: This machine requires 8 gauge – 75° main power cord.**

Refer to instructions in the following section for instructions to power up or shut down the machine.

### Special Notes About the Bundling Tunnel Shutdown Sequence

- ▶ When shutting down the tunnel, be sure to first turn the heater-bank switch to Off.
- ▶ Once the heater-bank switch is switched off, it will take some time (this will vary depending on heat settings) for the tunnel to cool down completely.



- ▶ When the tunnel cools down to approximately 150°F or 66°C (unless a different cool-down temperature has been set), the tunnel conveyor and blowers will shut off automatically.
- ▶ Bringing the tunnel down this way helps prevent damage to the conveyor and internal components from excess prolonged exposure to heat inside the tunnel.
- ▶ When the tunnel is in the resulting standby state, it shuts off the power to the conveyor and heating elements but the lights and controller use only minimal power in a standby state. This allows the tunnel to be readily brought up for the next production run once the heater bank is switched on and the rest of the normal daily sequence of operation is followed.
- ▶ It is not necessary to shut the main power lever Off and then move it back to the On position to “reset” or “reboot” the system after each production run, and this can actually result in undue, premature wear of the main power switch.

# Operation

## Main Power Disconnect

**Power** — The power disconnect switch is the lever with the orange handle on the right side of the electrical box in the base frame below the tunnel

- Lifting the lever to the On position turns on (connects) the system power necessary to power the Eastey Bundling Tunnel.
- Pushing the lever down to the Off position cuts (disconnects) all power to the system.

**Note:** See the **Special Notes About the Bundling Tunnel Shutdown Sequence**, later in this section.

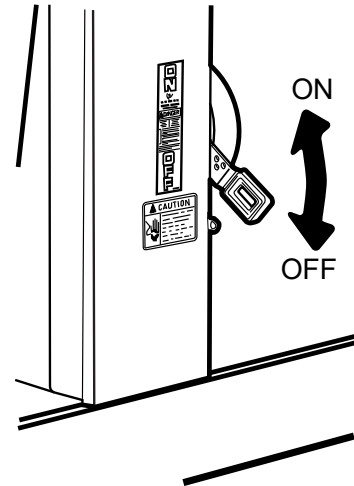

## Control Panel

The control panel contains controls for the conveyor speed, heater bank on or off, and blower speed, all in a central location. It is located on the side of the tunnel near the top of the unit.

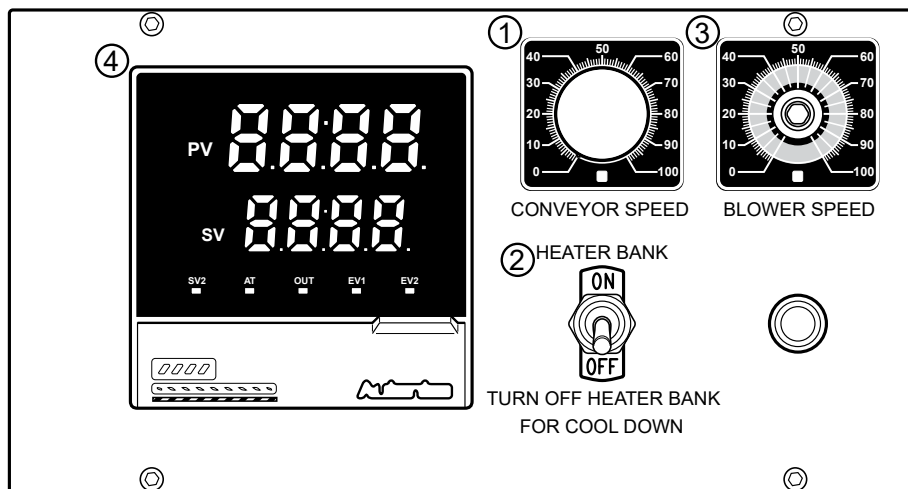

1. **Conveyor Speed** — Speed setting dial control for controlling speed of the conveyor.
2. **Heater On-Off Switch** — Toggle switch for turning the heater bank on or off.
3. **Blower Speed Control** — Speed setting control for blower speed.

4. **Thermostat Control** — Temperature setting (SV, for Set Value, also sometimes called the set point) and current temperature (PV, for Present Value) inside the chamber is displayed.

**CAUTION!** When the power is turned on be aware of heat inside of the tunnel and hot surfaces and moving belts or rollers.

## Sequence of Operation

1. If the Main Power Disconnect lever has not been lifted to the On position, turn on power to the bundling tunnel by lifting the Main Power Disconnect lever to the On position. (It should not be necessary to turn this lever off and on in the normal day-to-day operation of the bundling tunnel. See the Special Notes About the Bundling Tunnel Shutdown Sequence at the end of this section.) The temperature in the tunnel will be displayed on the thermostat control.
2. Turn the Heater Bank toggle switch below the conveyor speed control dial to the On position. (This switch also controls all motors.)
3. Set the conveyor speed control at about midrange for initial operation. This can be fine-tuned later. (Exact desired conveyor speed can be determined later, based on package size and sealer speed.)
4. Set the temperature controller to the temperature recommended for your shrink-wrap material. This temperature may need to be adjusted higher or lower until you have achieved satisfactory shrink sealing. Once the correct temperature for a product has been set, you should not need to adjust the temperature again as long as you are running the same product.
5. Adjust the blower speed or chamber ventilation for proper air flow.
6. Turn on the product cooling fan. There is a three-speed selector switch on the cooling fan. Adjust the cooling fan speed to help shrink the film. (Polyethylene film shrinks as it cools.

**CAUTION!** When shutting down the tunnel, be sure to turn the Heater Bank toggle switch to Off and wait for the tunnel to cool down. (Refer to the procedure for setting the cool-down temperature. Temperature will be displayed on the thermostat control.) Once cool-down temperature is reached the conveyor and blower motors will shut down and stop. It is not necessary to shut off Main Power for normal day-to-day operation. See the following Special Notes About the Bundling Tunnel Shutdown Sequence.

## **Special Notes About the Bundling Tunnel Shutdown Sequence**

- ▶ When shutting down the tunnel, be sure to first turn the heater-bank switch to Off.
- ▶ Once the heater-bank switch is switched off, it will take some time (this will vary depending on heat settings) for the tunnel to cool down completely.
- ▶ When the tunnel cools down to approximately 150°F or 66°C (unless a different cool-down temperature has been set), the tunnel conveyor and blowers will shut off automatically.
- ▶ Bringing the tunnel down this way helps prevent damage to the conveyor and internal components from excess prolonged exposure to heat inside the tunnel.
- ▶ When the tunnel is in the resulting standby state, it shuts off the power to the conveyor and heating elements but the lights and controller use only minimal power in a standby state. This allows the tunnel to be readily brought up for the next production run once the heater banks are switched on and the rest of the normal daily sequence of operation is followed.
- ▶ It is not necessary to shut the main power lever off and then move it back to the On position to “reset” or “reboot” the system after each production run, and this can actually result in undue, premature wear of the main power switch.

# Adjustments

## Temperature Controller Settings (ETC00011)

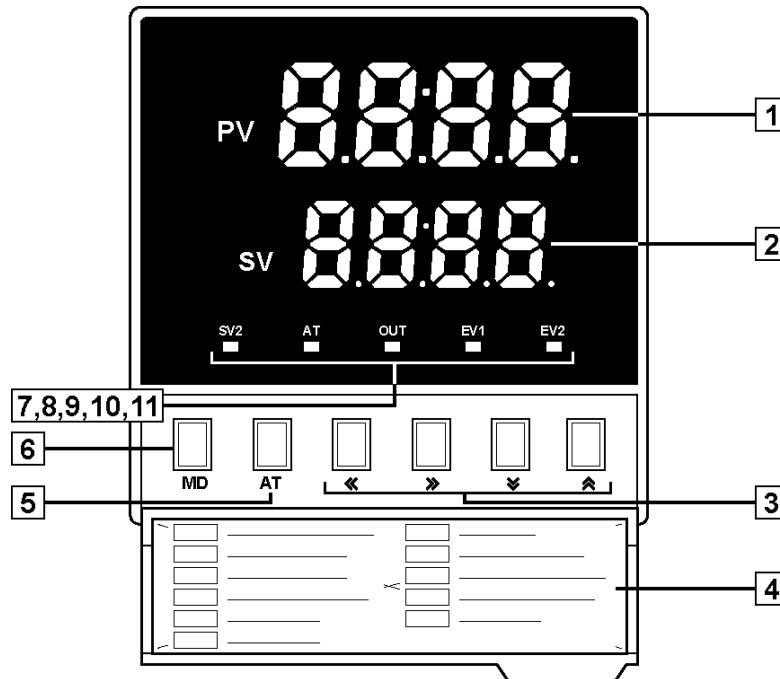

1. PV = Processing value (red in color).
2. SV = Setting value (green in color).
3. Back (◀), forward (▶), down (▼), and up (▲) keys.
4. Programming key access door — Open to access programming keys.
5. AT key: the mode key to execute Auto Tuning function.
6. MD key: the mode key to change items to be set, such as set value, etc.
7. EV2: Event 2 output signal lamp.
8. EV1: Event 1 output signal lamp.
9. OUT: Main output light to indicate when heater bank is are on.
10. AT: Signal lamp flashes while unit is auto-tuning.
11. SV2: Not currently used.

## To Change the Set Value

1. Press the left-arrow (◀) button and a digit will begin to flash. The flashing digit indicates the digit whose value can be changed by pressing the down- (▼) or up-arrow (▲) buttons.
2. If necessary, press the left- (◀) or right-arrow (▶) to shift to the place of the digit that needs to be changed. (The digit to the left or right will begin flashing.)
3. Press up (▲) or down (▼), as required to change the flashing digit to the required value.
4. Repeat instructions 2 and 3 above as necessary until all digits have been set to the required value, and then press the MD button. No digits will be flashing, the new value entered is applied.

## To adjust the Delay Cool-Down

The SV, for Set Value (also sometimes called the set point), is factory set to 400°. If you change this value, you must make the following adjustment to ensure that your equipment will automatically shut down at 150°.

PV, the Process Value is the actual temperature in the machine. PV and SV are mentioned in this procedure, but they are only displayed at the beginning of the procedure.

1. Press and hold the MD button until SV-1 is displayed.
2. Press the MD button (do not hold it down) repeatedly to scroll through the menu until LOC is displayed.
3. Press the left-arrow (◀) key. (ON will begin flashing.)
4. Press the down-arrow (▼) key. (ON will turn to OFF and OFF will be flashing.)
5. Press the MD button. (OFF will stop flashing.)
6. Press MD again. (This will bring you back to SV-1.)
7. Press MD again until AL-1 is displayed.
8. AL-1 is set to 250°. Optimum shut-down should be 150°.

Factory settings are as follows:

SV (Set Value, your set point) is set to 400°.

AL-1 is set to 250°

$400^{\circ} - 250^{\circ} = 150^{\circ}$

To set AL-1 so the machine will shut down at 150°, press the left-arrow (◀) key and the right-most digit will flash. Use the up- (↑) or down- (↓) arrow key to select the digit, and then press the left-arrow (◀) key again. Use the up (↑)- or down arrow (↓) key to set the digit and repeat until the correct value is displayed. Press MD to lock in the setting.

9. Press MD and scroll through the menu until LOC is displayed.
10. Press the left-arrow (◀) key. (OFF will begin flashing.)
11. Press the up-arrow (↑) key. (OFF changes to ON, and ON is flashing.)
12. Press MD. (On stops flashing.)
13. Press and hold the MD key until PV and SV temperatures are displayed.

### **To Access Temperature Controller Menu Options** (ETC00011)

1. Press and hold the MD button and the up-arrow (↑) key for approximately 4 to 5 seconds until IN-T displays.
2. Press the MD button (do not hold it down) repeatedly to scroll through the menu.
3. When you have scrolled to the option to be changed, press the left-arrow key (◀) twice to select the option.
4. Press the up-arrow (↑) key to increase the value or the down-arrow (↓) key to decrease the value.
5. Press MD and scroll through the menu until LOC is displayed to lock in the changed value.
6. Press MD to return to normal display.
  - To unlock settings, scroll to LOC and press the left-arrow (◀) key twice, and then press the (↓) down-arrow key.
  - To access the temperature controller second menu (Menu 2), press and hold MD for approximately 4 to 5 seconds until Su-2 displays.
  - To return to the main menu (Menu 1), press and hold MD.

Refer to the Troubleshooting section of this User Guide for Temperature Controller Default Settings.

# Maintenance

To aid in the high reliability of the bundling tunnel, inspect the machine regularly and perform maintenance as required. Disconnect electrical power before making any repairs. Be very careful when servicing or adjusting this equipment. If in doubt, stop and obtain qualified help before proceeding.

**CAUTION!** When replacing motors, if the tunnel chamber is below 160 degrees, the heater bank switch may need to be turned on to apply power to motors for testing.

## Preventative Maintenance

- Lubricate roller chains every 60 hours with a high temperature oil. Use a brush to apply lubricant while running the conveyor slowly.
- Inspect the rollers of the conveyor regularly to ensure that no scrap pieces of film are wrapped around the rollers to cause sticking packages.

### To Clean Rollers:

- Run the conveyor until the affected rollers are inside the heat chamber to heat the film residue and soften the film so it will clean easier.
- Advance and then stop the conveyor so the heated rollers are out of the chamber and accessible for cleaning.

**CAUTION!** Make sure the conveyor is stopped before putting your fingers or anything else in the conveyor area.

- Remove film residue. If necessary, use a dull blunt-edged tool. Do not use any sharp instruments, as nicking silicone may result in damage that requires replacing the roller covering.

## Perform the following maintenance checks each month.

- Check and clean the intake screens.
- On dead roller tunnels, clean and lubricate the conveyor chains. Check the chains and adjust as needed.
- Check the condition of the silicone covering on the rollers. Repair or replace as necessary.
- On plastic belt conveyors, check for material stuck in or on the belt. Check and adjust the belt tension as needed.
- Check and clean the motor-to-conveyor drive chain. Adjust tension as needed.
- Check for loose fasteners. Tighten as necessary.



- Check the condition of the power cord for wear, especially if it is exposed to traffic.
- Check that the tunnel is able to maintain the set temperatures. If not, refer to the Adjustments Section of this User Guide for instruction.
- Check that you are able to vary the conveyor speed. If not, refer to the Adjustments Section of this User Guide for instruction.
- Check for overall wear on dead roller guide rails and starter rails. Repair as needed.
- On plastic belt conveyors, check the condition of the plastic belt. Repair or replace as needed.
- Check the condition of all warning and instruction labels. Replace as necessary.

## **Preventative Maintenance for Modular Plastic Conveyor Belts**

Modular plastic conveyor belts typically do not require day-to-day maintenance and are generally trouble-free when installed and operated properly.

Following are a few recommendations to obtain maximum life of the belt and avoid down-time.

- Check belt tension on a routine basis (weekly or monthly) to ensure proper drive. Adjust screw take-up if necessary. (Belts experience thermal expansion while hot.)
- Sprocket alignment should be checked before installing the belt to ensure that all the teeth are in line. (A misaligned sprocket can cause the belt to break or go off track.) On round-bore sprockets, it is good practice to check the keyways and tighten keyway setscrews when required.
- If a small section of the belt or a module breaks, it is important to replace it as soon as possible. Failure to do so could incur further damage to the belt. Try to determine the cause of the break before restarting to avoid the break from happening again.

Make sure that when you join the belt, the metal connecting rod is locked in with a plastic tab.

- To replace a belt section See the Belt Assembly and Disassembly section that begins on page 30 and outlines procedures To assemble the belt on page 30 and To disassemble the belt on page 31.
- Remove a steel connecting rod by pulling it out from the left.
- To lock the tab in, put the tab in from the top of the belt and press it into place.

- When performing repairs to the conveyor, it is important to remove or protect the belt to avoid damage from welding sparks or from other tools.

Avoid using the belt for uses other than for what it was specified. If you need to utilize the belt in a different application, consult the manufacturer first.

## Conveyor Belt Tension Adjustment

Check the belt tension of the package conveyor occasionally to ensure that it is not excessive, as this will cause unnecessary wear on the conveyor sprockets.

To check or adjust tension, shut off power to the tunnel, remove the drive end caps, and loosen the two outer jam nuts on the drive end of the conveyor. Adjust the tensioning bolts as required to for correct belt tension. (Belt should touch lower rails approximately 11 inches in from the outside edge of the leg). If there is no more adjustment available through the tensioning bolts, a link can be taken out. To remove a link, loosen the belt by removing two (2) pins. (Remove the plastic keeper tab on the end of the pin.) Eliminate one row of links, pull the conveyor belt together, and reinsert one (1) pin. A new plastic keeper must be used to hold the pin in place.

### To Check or Adjust Conveyor Chain Tension

1. Bring a roller to the three o'clock position (the center of the end) of the idler end of the conveyor.
2. Shut off power to the tunnel, and then remove the idler end caps.
3. Begin with the roller in the three o'clock position and count the conveyor rollers. The seventh roller should be evenly touching the conveyor starter rails.

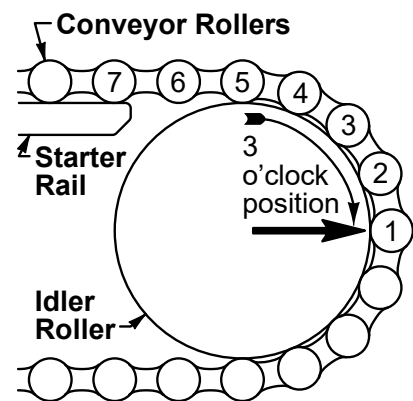

## Replacing Conveyor Components

**Caution!** Disconnect main power source before performing any procedure to replace any conveyor component(s).

### Roller Silicone Covering Replacement

1. Disconnect power to the machine.
2. Remove idler end caps, disconnect drive chain, loosen the four (4) bolts that hold the drive motor and then, through the access hole, take the drive chain off the drive motor sprocket.

**NOTE:** You must take the chain off the drive motor sprocket or the conveyor will not move freely. You must be able to move the conveyor to replace silicone covering on the rollers.

3. Remove old covering, by carefully slitting the covering and then pulling it off.
4. Clean all rollers using steel wool or a wire wheel. Make sure all rollers are smooth and free of residue and burrs.
5. Fit the new silicone rubber tubing onto each roller and work on by hand at least  $\frac{1}{2}$  inch. At the opposite end of the tubing, fit on and secure an air supply hose of low pressure, maximum pressure 5 lbs. While tubing is slightly expanded by air pressure, push the tubing onto the roller and work it on to the roller. Be careful to hold the roller at all time so it does not fly from the air pressure.
6. Replace rollers on conveyor by inserting roller end holes into the extended pins of the chain. Reconnect drive chain around drive motor sprocket. Adjust tension on drive chain by retightening the four (4) bolts. Place access-hole cover back on, and replace idler end caps.
7. Check conveyor chain tension by following the steps explained earlier.

### **Idler, roller shaft, bearings, or sprockets replacement**

Refer to the Roller Silicone Covering Replacement section above to access and remove rollers as required. Note the location and orientation of sprockets (make a sketch and note measurements if necessary). Loosen the jam nuts on the tensioning bolts at the drive end of the conveyor. Remove the four (4)  $\frac{1}{4}$ -20 bolts for the bearings. Slide the shaft left or right and then the shaft and sprockets will come off. Identify and replace any damaged or worn parts and reassemble in reverse order of disassembly.

### **Drive shaft, bearings, or sprockets replacement**

Refer to the Conveyor belt tension adjustment section above to open up the conveyor belt. Remove the drive end caps. Disconnect the conveyor belt. Note the location and orientation of sprockets (make a sketch and note measurements if necessary). Loosen four (4) set screws on the drive sprockets. Keep the keyway key for the driveshaft and replace as necessary. Slide the shaft left or right. The shaft sprockets must be adjusted for position. All sprockets are fastened to the shaft by set screws. Identify and replace any damaged or worn parts and reassemble in reverse order of disassembly.

### **Conveyor motor replacement**

Shut off the machine and disconnect main power. Remove the drive end cap, disconnect two (2) electrical wires from the drive motor, and disconnect the motor from the drive chain by removing four (4) bolts that hold the drive motor. Remove the sprocket from the old motor and place it on the new drive motor and reassemble parts in the same as they were disassembled. For electrical connections, refer to the electrical schematics.

## Replacing Tunnel Components

**Caution!**      **Disconnect main power source before performing any procedure to replace any tunnel component(s).**

### Fuse replacement or electrical component replacement

Major electrical components, except the conveyor motor (whose replacement procedure is provided on the previous page) and the heater bank and blower motor (whose replacement procedures are provided separately below), are located behind the fold-down electrical control panel for easy maintenance. See the Panel Layout in Appendix A for description and approximate location of electrical components.

### Heater bank replacement

Shut off the machine and disconnect main power. Remove the side panel cover. Pull insulation out. Marking the wire positions so they can be reconnected in the same positions, remove the wires on the heater bank with a 3/8-inch nut driver, and then set the wires off to the side. Noting the heater bank position so it can be replaced in the same position, remove the heater bank. Reassemble components in the same manner in which they were disassembled.

**Important!**      **Ensure that the heater bank frames are pushed completely in. The end of the frame should be flush with the housing.**

### Temperature controller replacement

**Note:**              **Shut off power to the machine before opening the panel door on the side of the machine to access internal electronics and temperature controller.**

There are two options for removing the temperature controller.

1. The first and easiest option is to remove and replace only the controller, which reuses the receptacle sleeve and leaves all wiring intact.
2. The second option is to disconnect all wiring and replace the controller and sleeve together.

To reuse the housing and replace only the interior components of the controller, use a flat screwdriver to carefully press down on the tab, inside on top of the controller. (Take care to not break or deform the tab permanently. See the following illustration.) While the tab is depressed, pull on the front face of the controller to slide it out of the housing.

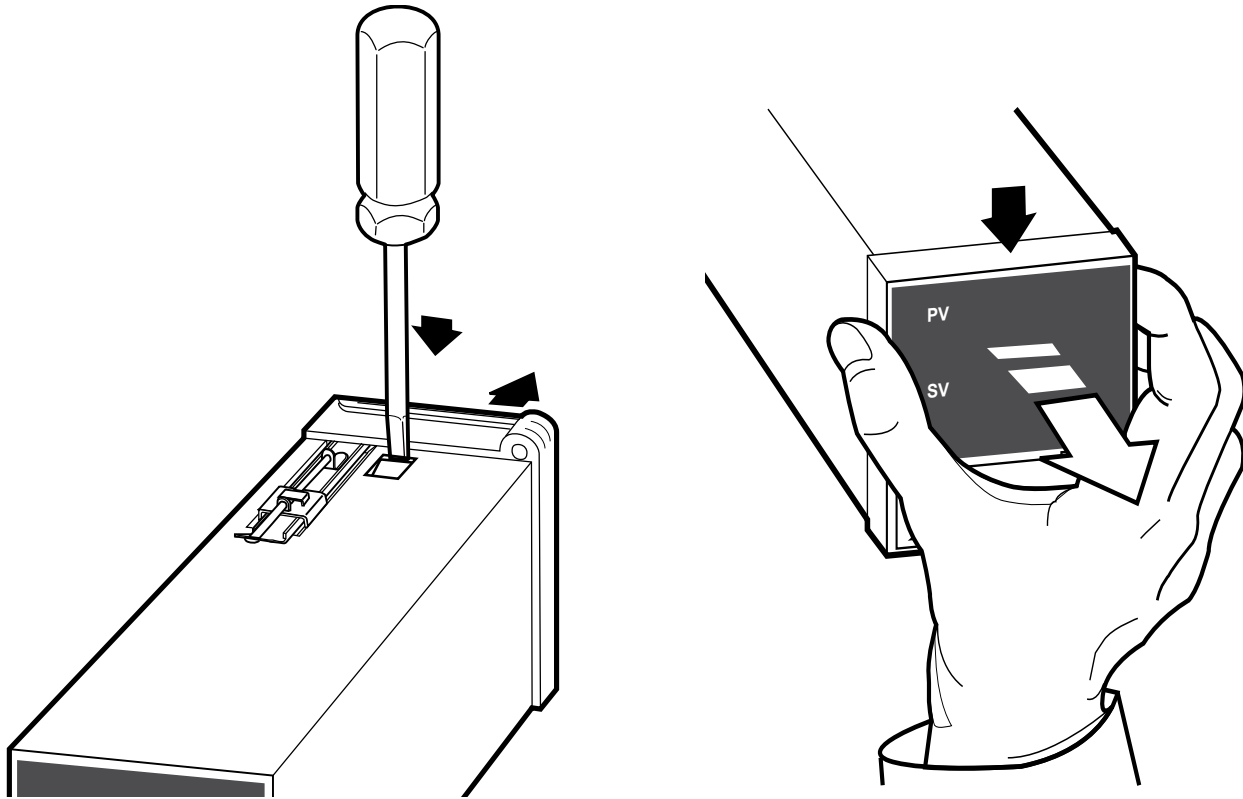

For the second option (to replace entire controller and receptacle), first take note of wire locations (make a sketch and label the wires with tape, if necessary), and then disconnect wires from the temperature controller and thermocouple. Slide the controller and receptacle out of the front of the panel. Replace with a new controller and reconnect wires to the temperature controller and thermocouple. (Refer to notes made during disassembly or the electrical schematic if necessary.)

**Warning:** If there is no control over heat, interchange the thermocouple wires.

**Caution:** Do not exceed 500 degrees.

### Blower motor replacement

Shut off power to the machine. Remove the top lid on the hood of the tunnel. Disconnect the wires on the blower motor(s). (Note: there may be more than one blower motor.) Remove four (4) 5/16-18 bolts on the motor mount(s). Once the blower housing is out and on the bench, loosen the two (2) set screws holding the blower wheel in place. The blower wheel shaft set screws are installed with thread-locking compound and may require a torch to remove the blower wheel — if force is necessary, apply it between the motor and blower wheel hub. Remove the motor mount bolts and remove and replace the motor. Rotation on the blower motor needs to be counter-clockwise as viewed from the electrical inlet and hub side. Reassemble the new motor and blower wheel housing and reassemble components in the same manner in which they were disassembled.

**Note:** Do not rest blower housing on blower wheel! Blower wheel will not work if bent or out of balance.

### Blower wheel replacement

Shut off power to the machine. Refer to **Blower motor replacement** instructions above.

### Placement of upper wear rails

Shut off power to the machine, move the conveyor by hand if necessary to gain access. Remove the #10-32 screw on the idler end. Replace parts in the same manner in which they were disassembled.

### Chamber cooling fan motor replacement

Shut off power to the machine. Remove the top lid of the hood. Disconnect the wires. Remove four (4)  $\frac{1}{4}$ -20 screws which hold the cooling fan motor in place. Take the motor out of the machine, replace with the new motor, and reassemble with four (4)  $\frac{1}{4}$ -20 screws removed earlier. Reconnect wires to new cooling fan motor.

### Belt Assembly and Disassembly

When repairing or replacing the belt, it is important to orient the belt correctly.

- The top side of the belt is relatively smooth and the ribs are recessed.

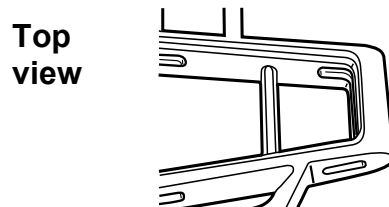

- The bottom side of the belt has metal disks visible and the ribs are flush.

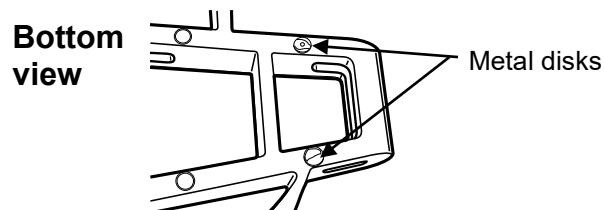

### To assemble the belt

1. Bring ends of the belt together, and aligning holes, insert metal rod through holes for the entire width of the belt.

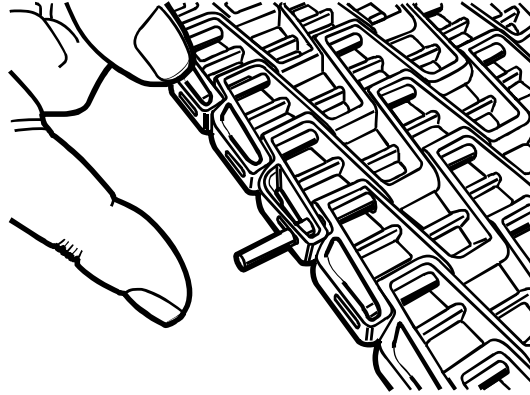

2. Insert a plastic retainer clip into place to retain the metal rod. Use a hammer, if necessary, to gently tap the retainer clip into place.

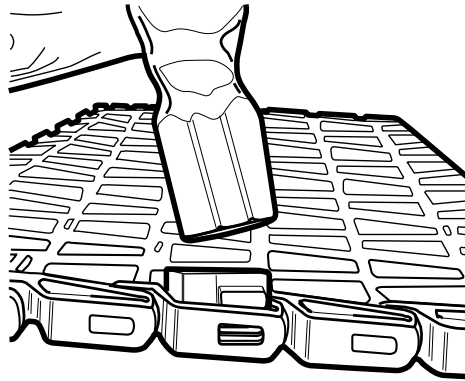

3. Use a flat-blade screwdriver to give the retainer clip a “double click” to finish seating it in place



### To disassemble the belt

1. Place a block under the belt and place the belt upside-down over the block, so the link to be opened is positioned close to the block.

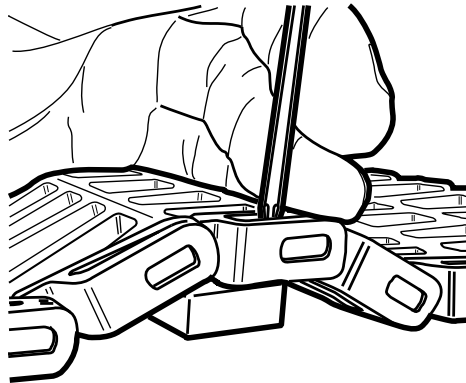

2. Use a screwdriver to push down on the retainer clip to unseat it.

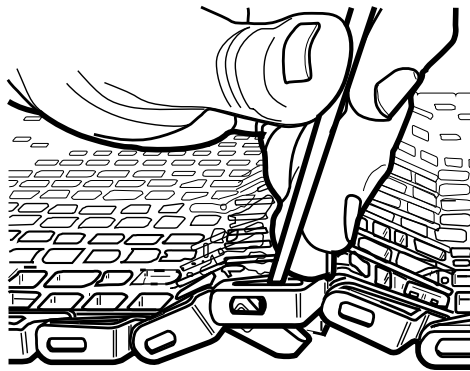

3. Continue to push down on the retainer clip to move it out of the end link.
4. Slide the metal rod out to unlink the belt and the belt will unzip.



# Troubleshooting

The following illustration shows the D.C. board used in the bundling tunnel. Some of the solutions to problems identified in the troubleshooting table that follows refer to adjustments made by tuning potentiometers on this board.

## Basic KBMM™ Controller Board Connection Diagram

## KBMM™ with Barrier Terminal Kit

CONTROL LAYOUT & GENERAL CONNECTION DIAGRAM (Model KBMM-225D Shown)

(Note: Control is set for 208/230 VAC line input, 0-180 VDC output with armature feedback)

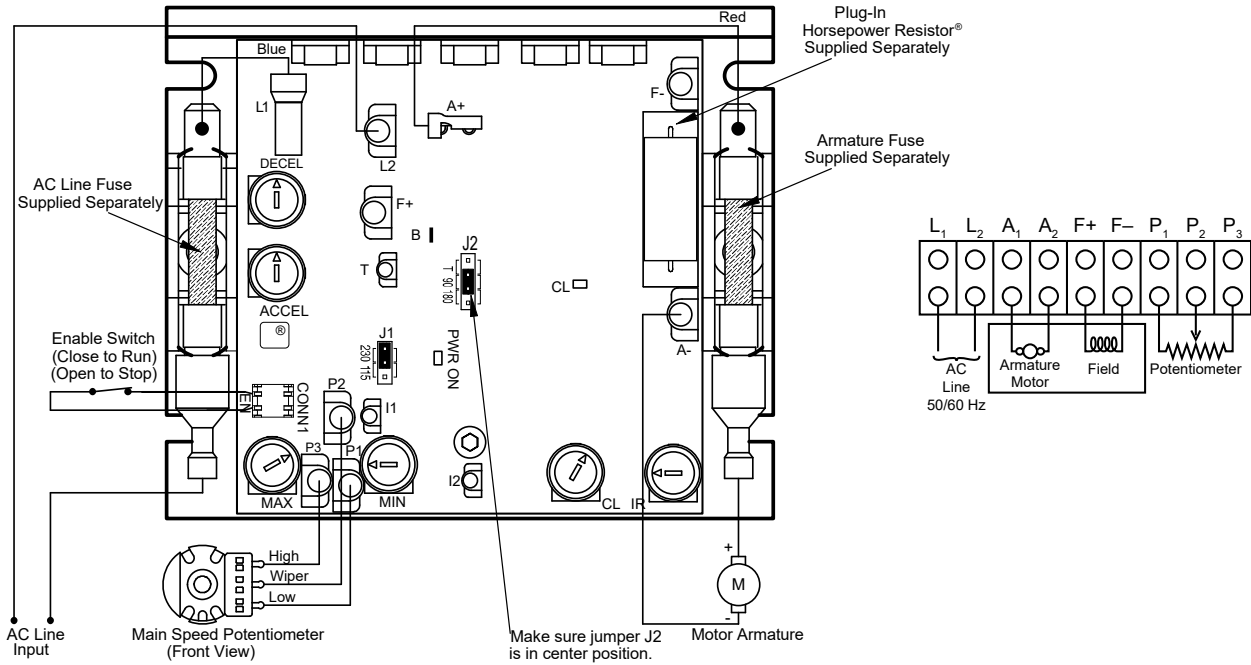

For more information refer to the KBMM™ *Installation and Operation Manual* (provided by the D.C. board manufacturer).

Problem	Solution
Conveyor not moving	<ol style="list-style-type: none"><li>1. The conveyor motor is controlled by a D.C. control board. Input is 220 VAC in and variable 0 to 90 VDC out.</li><li>2. Is a green light on? If not, check the input fuse.</li><li>3. If fuse is good and a green light is not on, check for 220 VAC on L1 and L2. If there is voltage, check the output DC voltage.</li><li>4. Check output fuse.</li><li>5. The KBMM-225 has a current overload. Is there a red light on the board? If so, below are some conditions that could cause this light to turn on.<ul style="list-style-type: none"><li>• This could be caused by a jammed conveyor.</li><li>• Locate the ceramic horsepower resistor and check its resistance. If the ohmmeter indicates open (infinite resistance), the resistor is damaged; replace it — but, there is a reason the resistor went out. There will be a point number (for example, .1 or .25) you will need this number when ordering a replacement resistor.</li><li>• The motor is pulling more amps than the board is allowing. Try adjusting the CL potentiometer on the motor controller board.</li><li>• Bad idler or drive bearing.</li></ul></li><li>6. If the red light is on, disconnect the drive motor from the drive chain. Power up the machine and operate the motor without any load and see if the red light goes off. If the board works and the red light does not light, it does not mean that the motor is good; it could be weak under load. Check the brushes. Also pull the conveyor by hand, checking to make sure it pulls smoothly and checking for bad bearings.</li><li>7. If the light remains on, replace the motor.</li><li>8. If the red light is not on and a green light is, with the speed pot set at 100%, check for 90 VDC on terminals A+ and A-. If voltage is not correct, try adjusting the MAX potentiometer to obtain 90 VDC.</li></ol>

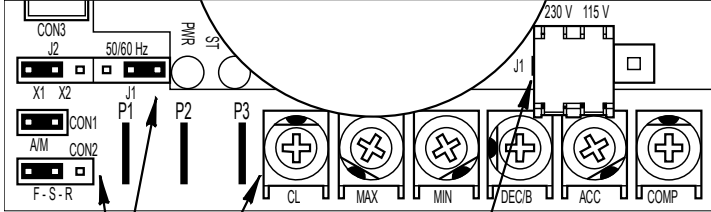
Problem	Solution
<p>No air flow</p>	<ol style="list-style-type: none"> <li> <p>Check AC Inverter adjustable speed pot settings below.</p> <ul style="list-style-type: none"> <li>C.L.: Set at approximately 12 o'clock.</li> <li>Max.: All the way counter-clockwise.</li> <li>Min.: All the way clockwise.</li> <li>ACC.: All the way clockwise.</li> <li>Comp.: Set at approximately 12 o'clock.</li> </ul> <p style="text-align: center;"><b>Detail View of Jumpers and Trim Pots</b></p>  <p style="text-align: center;">Jumpers and Trim Pots (Shown in Factory Setting) (Located on Lower PC Board)</p> <p style="text-align: center;">Line Voltage Selection Jumper J1 (Located on Upper PC Board) (Models KBVF-21D, 22D, 23D, 24D &amp; 26D Only)</p> <p><b>Important Application Information:</b></p> <p>Motor with External Fan Cooling – Most totally-enclosed fan-cooled (TEFC) and open-ventilated 3-phase AC induction motors will overheat if used beyond a limited speed range at full torque. Therefore, it is necessary to reduce motor load as speed is decreased.</p> <p><b>Note:</b> Some fan-cooled motors can be used over a wider speed range. Consult the motor manufacturer for details.</p> <p><b>⚠ WARNING!</b> Some motors have low speed characteristics which cause overheating and winding failure under light-load or no-load conditions. If the motor is operated in this manner for an extended period of time, it is recommended that the unloaded motor current be checked from 1–15 Hz (60 – 450 RPM) to ensure motor current does not exceed the name-plate rating. Do not use motor if the motor current exceeds the nameplate rating.</p> </li> <li> <p>Check intake screens inside upper chamber to see if they are clogged.</p> </li> <li> <p>Blower motors are controlled by 220 volt single-phase input and three-phase output. (Check lead to lead. Not lead to ground.)</p> </li> <li> <p>Is there a steady green and a slowly-flashing green light? If not, check input fuses. If fuses are good, replace AC inverter.</p> </li> <li> <p>If there is a steady green light and not a slowly-flashing green light, refer to the table that follows for information about what the flashing LEDs indicate.</p> </li> </ol>

LED	Drive Status	Color and Flash Sequence	Flash Rate	Color and Sequence After Recovered Fault
	Normal Operation (Run)	Green	1 sec. On / Off	—
	Overload (120% – 160% Full Load)	Red	On continuously	Green
	I <sup>2</sup> t (Drive Timed Out)	Red	0.25 sec. On / Off	—
	Short Circuit	Red	1 sec On / Off	—
	Under-Voltage	Red / Yellow	0.25 sec. On / Off	Red / Yellow / Green
	Over-Voltage	Red / Yellow	1 sec. On / Off	Red / Yellow / Green
	Stop	Yellow	On continuously	—
	Phase Loss Detection <sup>1,2</sup>	Yellow	0.04 sec. On / 0.06 sec. Off	—
	Communication Error <sup>2</sup>	Green / Red	1 sec. On / Off	Green
PWR (Power)	Bus and Logic Power Supply	Green	On continuously	—

**Notes:**

1. Phase Loss Detection: Models KBVF-23P, 24P, 29, 45, 48.
2. Requires AC line restart.
3. With DVF Modbus Communication Module Installed.
4. All LED flash rates after recovered faults are 1 sec. On / Off.
5. Drive will require manual restart to return the Status LED color to its normal flashing green state.

Problem	Solution
No air flow (Continued)	<ol style="list-style-type: none"> <li>6. If one motor is running and one is not, replace the faulty motor.</li> <li>7. If all motors are not running, check for approx. 220 VAC output voltage. If there is no voltage and the green lights are on and slowly flashing, replace the AC inverter. (Remember this is three-phase: test from lead to lead. Do not test to ground.) U to V, U to W, V to W. If you lose voltage on one of these legs, replace the AC inverter.</li> <li>8. One bad motor could cause the steady-flashing green light to change. Disconnect all motors and run one motor at a time to find the bad motor.</li> <li>9. Motors should be running counter-clockwise. Check that all motors are running the correct direction. If not, change the two output terminals to obtain correct phase.</li> </ol>

Problem	Solution
No heat	<ol style="list-style-type: none"> <li>1. Is the display on the temperature controller on? If not, check for 220 Volts on terminals 9 and 10. If there is voltage, replace the temperature controller.</li> <li>2. If the display is on and SV is set higher than PV, is there a red light on? If not, replace the thermocouple.</li> <li>3. If there is a red light on, check for 220 VAC from any wire number 8 to terminal 13, and then terminal 14. If no voltage, replace the temperature controller.</li> <li>4. If there is 220 VAC, check for 220 VAC on coil of heater contactor. If there is voltage and the contactor is not pulling in, replace contactor.</li> <li>5. If there is no 220 VAC, check heater bank on / off switch. The best way to check this is to disconnect the wires and check resistances (Ohms).</li> </ol>
Delay cool-down does not work	Adjust temperature controller TT1 using the menus, Menu #1 and Menu #2, that follow. Refer to adjustment procedure to adjust the Delay Cool-Down setting.

### Temperature Controller Default Settings

#### Menu 1

In-t - JIC.H  
 Eu-1 - AL-0  
 Eu-2 - AL-5  
 AL-T - AL-B  
 AT.T - TUN1  
 PIDT - PID.F  
 O-FT - HEAT  
 Unit - ° F  
 H-SC - 450°  
 L-SC - 32  
 Ramp - OFF  
 LOC - ON

#### Menu 2

Su-2 - 32  
 AL1 - N/A  
 AL2 - 450  
 AHYS - 2  
 P - 9.5  
 I - 48  
 D - 12  
 T - 50  
 IN-B - -4  
 REST - 2.0  
 LOC - ON

# Parts List

## ETB3012-V2 & ETB3020-V2 220VAC 50 Amp 3 Phase Spare Parts List

Part Number	Description
ETC00304	Blow Cool Motor
ESC00641	14" Cooling Fan
ETL001001	60 Amp 3-Pole Contactor
ETC00021	Thermocouple
ETC00011	Temperature Controller
ET000205	10 Amp Small Glass Fuse
ET000185	2.5 Amp Small Glass Fuse
ET000186	5 Amp Small Glass Fuse
ESC00071	0.05 Resistor
EAST1009	20 Amp 250V Fuse
EAST0349	A/C Speed Control
EAST0315	DC Control Board
EAST0210	1 Amp Small Glass Fuse
ETL00317	16 KW 220V 3 Phase Heater Bank
ETL00202	Large Blower Wheel
ETL00109	¾ HP Variable Speed Blower Motor
ETL00228	Conveyor Drive Motor
ET300019	Silicone Covered Rollers, 30"
ETC00008	Bearing 5/8" ID

# Appendix A: Electrical Schematic

## Electrical Schematic ETB3012-V2 & ETB3020-V2 220VAC 50 Amp 3 Phase

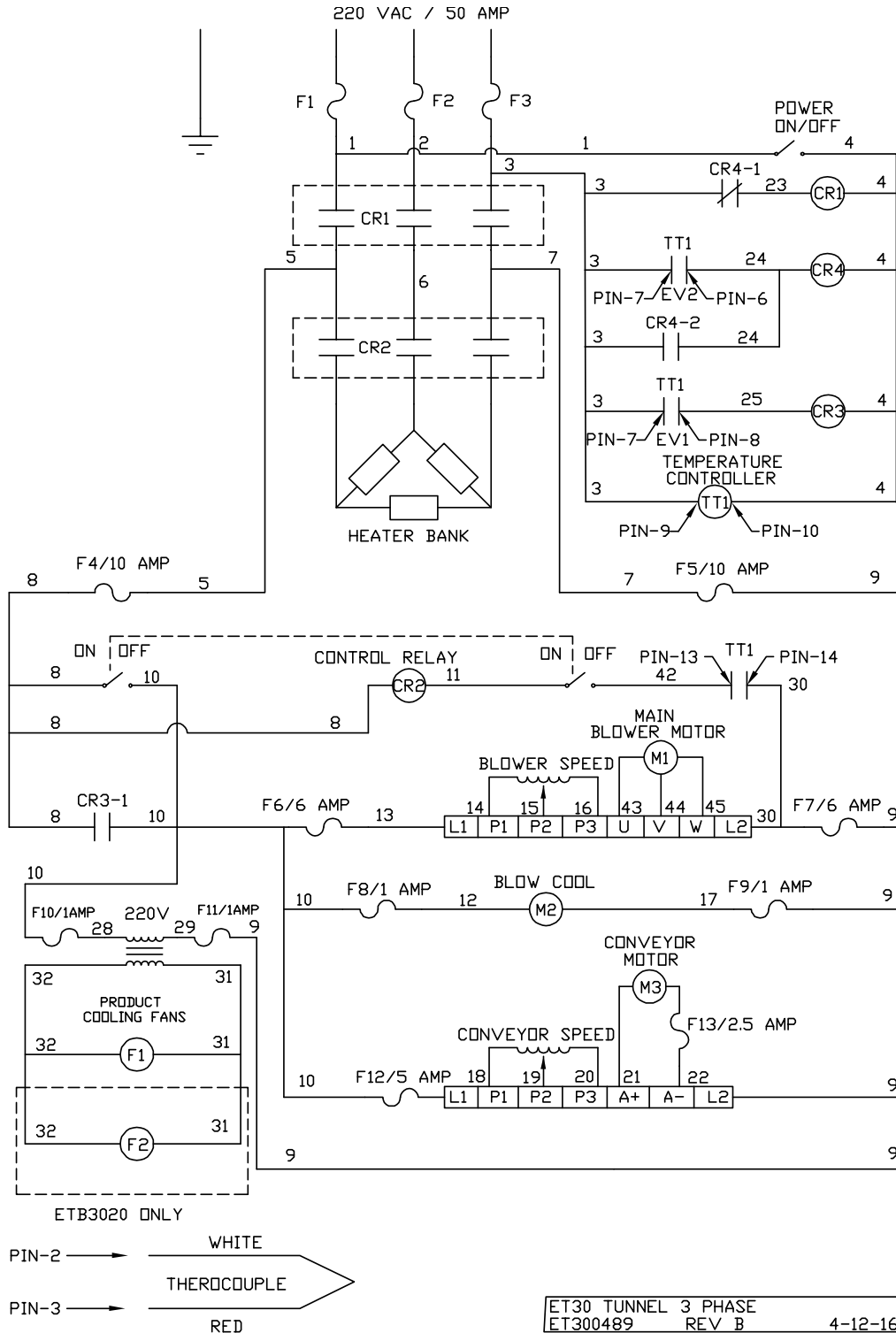

# Electrical Schematic ETB3012-V2 & ETB3020-V2 480VAC 25 Amp 3 Phase

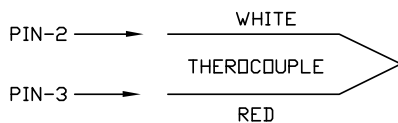
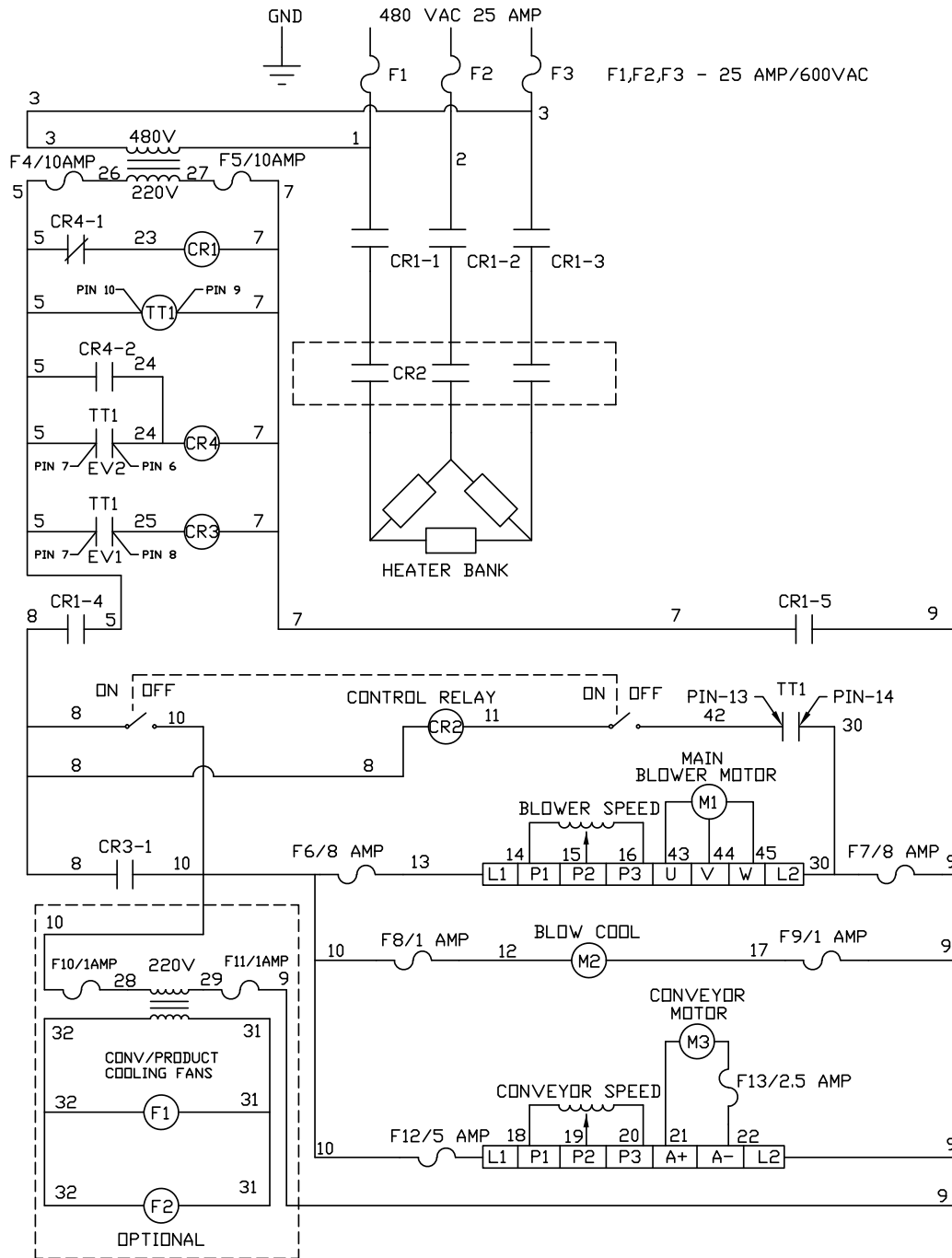

ETB3012/20 TUNNEL 480 VAC/3P 25A  
 ET300480 REV 2 12/13/19



## Motor Controller Board (KBMM™) Basic Connections for Controller Board and Barrier Terminal Kit

### Basic KBMM™ Connection Diagram

### KBMM™ with Barrier Terminal Kit

CONTROL LAYOUT & GENERAL CONNECTION DIAGRAM (Model KBMM-225D Shown)  
 (Note: Control is set for 208 /230 VAC line input, 0-180 VDC output with armature feedback)

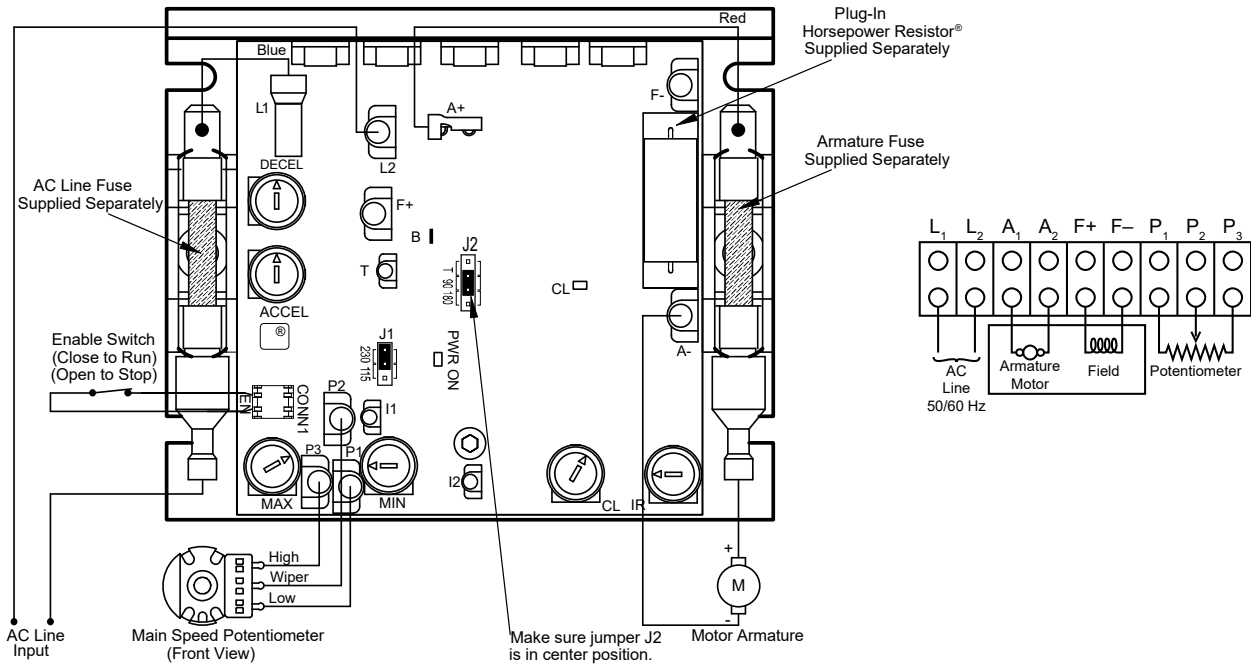

For more information refer to the KBMM™ *Installation and Operation Manual* (provided by the controller board manufacturer).

## Motor Controller Board (KBVF) Expanded View of Jumpers and Trim Pots, Controller Board for Blower Fans

### Basic KBVF Diagram

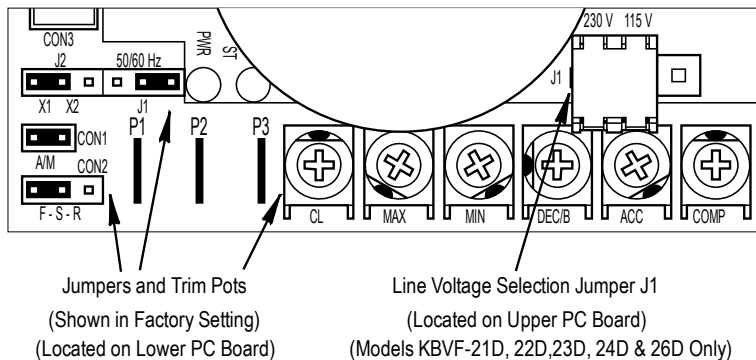

# Warranty Statement

## Eastey ETB3012 & ETB3020 Bundling Tunnels Performance Series

### Warranty Statement

Eastey warrants that all of the products it ships will be in good working order and free from defects in material and workmanship and will conform to the published specifications for that product.

### Warranty Period

1 year, except for moving parts which are subject to normal wear, tear and replacement which are warranted to be free from defects in material and workmanship.

Items with shorter warranty period or not under warranty include the following.

Silicone Tubing (Roller Covering)	30 days
End Curtains	30 days

Fuses are considered to be consumable items and not under warranty.

### Shrinking Quality

Shrinking quality achieved in a given application is dependent on the installation, the material handling, and the maintenance provided. Eastey makes no warranty that the quality achieved in an application will be the same as that achieved on a test piece in our demo facility.

### Shipping Policy

Customer pays all incoming shipping. If the item is defective and under warranty, Eastey pays return shipping charges for least costly method. If expedited shipping is desired, customer must furnish his shipping account and shipping fees will be charged to that account.

### Warranty Verification

If you conclude that a product may be defective and may be covered by warranty, obtain a Return Material Authorization number by calling our technical support number (toll free at 1-800-835-9344, or 763-428-4846 or Fax: 763-795-8867 or e-mail: info@eastey.com) Once an RMA number has been obtained, return the defective item to Eastey. Eastey will analyze the product and, if found to be defective, we will, at our option, replace or repair the item. If the item is found to not be eligible for warranty, you will be notified and may decide on disposition. Defective products will be replaced or repaired as promptly as possible.

### Warranty Eligibility

The warranty provided by Eastey is only to the original buyer.

### Limited Warranty

THE ABOVE WARRANTY IS EXCLUSIVE AND IN LIEU OF ALL OTHER WARRANTIES, WHETHER EXPRESSED OR IMPLIED, INCLUDING THE IMPLIED

WARRANTIES OF MERCHANTABILITY, FITNESS FOR A PARTICULAR PURPOSE AND NONINFRINGEMENT.

**Disclaimer of Damages**

REGARDLESS OF WHETHER ANY REMEDY SET FORTH HEREIN FAILS OF ITS ESSENTIAL PURPOSE, IN NO EVENT WILL EASTEY BE LIABLE FOR ANY SPECIAL, CONSEQUENTIAL, INDIRECT OR SIMILAR DAMAGES, INCLUDING LOST PROFIT OR LOST OPPORTUNITIES OF ANY TYPE ARISING OUT OF THE USE OR INABILITY TO USE THESE PRODUCTS EVEN IF EASTEY HAS BEEN ADVISED OF THE POSSIBILITY OF SUCH DAMAGES.

# Customer Support

## Eastey Technical Service

For help setting up or operating the ET Performance Series Bundling tunnels, please contact Eastey Technical Service at one of the numbers listed below.

Toll-Free Phone	800-835-9344
Phone	763-428-4846
Fax	763-795-8867
E-mail	<a href="mailto:info@eastey.com">info@eastey.com</a>
Web	<a href="http://www.eastey.com">www.eastey.com</a>

Thank you again for your purchase of Eastey products. We are pleased to be a part of your packaging needs.





***EASTEY***®