

SB-2/3EX-Auto

**Automatic
Case Taping System**

User Guide

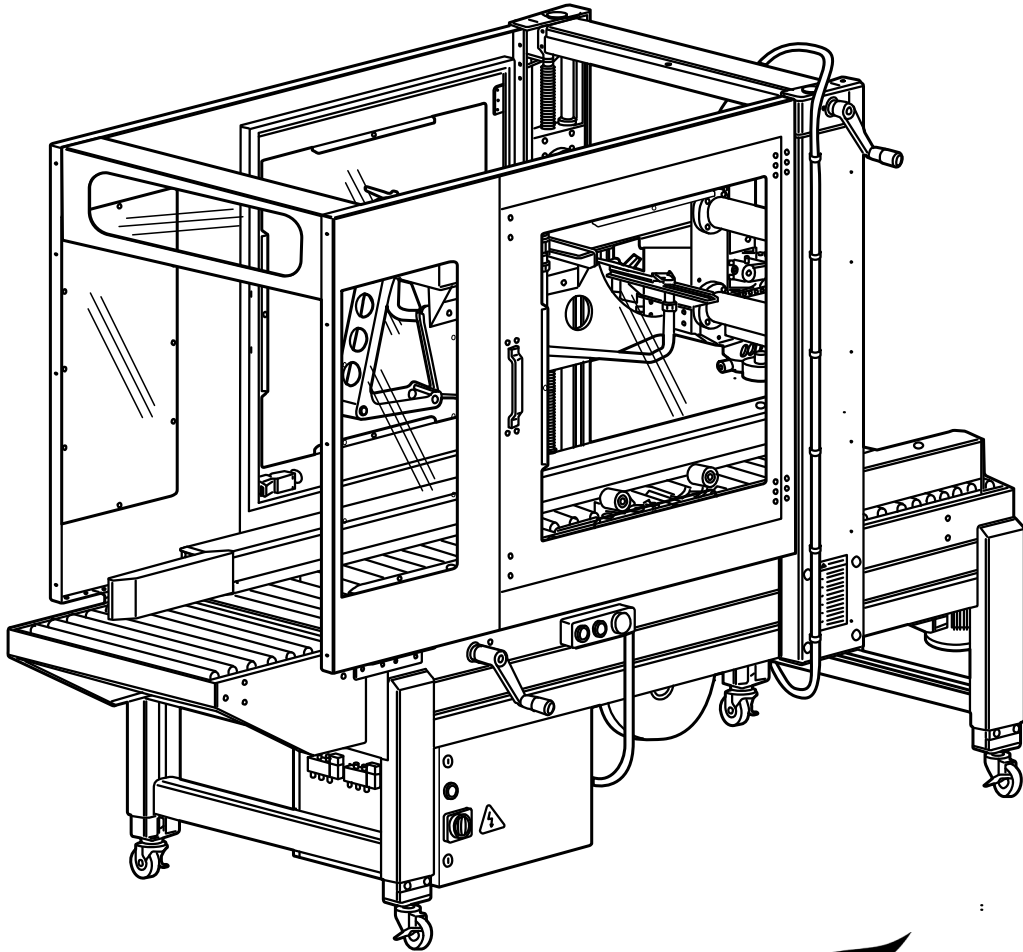

EASTLEY[®]

SB-2/3EX-Auto

Automatic Case Taping System

User Guide

Revised 05/31/2022

P/N 5001694 Rev B

Copyright and Trademarks

Copyright ©2012-2022 Engage Technologies Corporation
All rights reserved. All trademarks and brand names
are the property of their respective owners.

Eastey
7041 Boone Ave. N.
Brooklyn Park, MN 55428

Phone: (763) 428-4846; Fax (763) 795-8867; 1-800-853-9344

www.eastey.com

Contents

- Safety 7**
 - Explanation of Symbols..... 8

- Introduction 10**
 - SB-2/3EX-Auto Case Taper Overview..... 10
 - Specifications 11
 - Machine Serial Number..... 12
 - Typical Applications 12
 - Dimensions 13

- Installation 14**
 - Location Requirements 15
 - Optional Exit Roller Table 17
 - Next Steps..... 17

- Operation 18**
 - Loading the Tape Cartridges 18
 - Check Tension..... 19
 - Thread Tape 19
 - Main Spring Adjustment 21
 - Power and Control Panel 23
 - Power Switch Operation..... 24
 - Control Panel Operation..... 24

- Adjustments 26**
 - Air Pressure unit..... 26
 - Height and Width Adjustment..... 27
 - Top Squeezer Roller Width Adjustment..... 28
 - Flap Closing Guide Adjustment 28
 - Rear Flap Closer Speed Adjustment 29
 - Belt Adjustment 30
 - Photo Eye Location Adjustment for Drop Conveyor Gating and Rear Top Flap Closer
Kicker Timing..... 31
 - Machine Body Height Adjustment 35

- Maintenance 36**
 - Rollers..... 36
 - Cutting Knives 36

- Troubleshooting..... 37**

- Parts List..... 38**
 - Electrical..... 38
 - Pneumatic Parts..... 42
 - Side Belts 43
 - Vertical Column with Height Adjustment..... 46
 - Flap Guide and Upper Tape Head Seat Assembly 49
 - Machine Body 51

Infeed Index Roller Table.....	53
Options.....	55
Appendix A: Electrical Schematic	57
Warranty Statement	63
Customer Support.....	65

Safety

Read this manual carefully and make it available to everyone connected with the operation, supervision, or maintenance of this machine. Additional copies are available on request (Eastey.com/contact-us). Keep this manual with the machine at all times.

The development of a good safety program that is rigidly enforced is absolutely imperative when involved in the operation of industrial equipment. Our machinery is well designed and includes extremely important safety features. Proper installation, safe operation, and regular maintenance and upkeep are of far greater importance than out design. Only properly trained individuals, following rigidly enforced safety rules as recommended by ANSI and OSHA should be allowed to operate this machine.

Be very careful when operating, adjusting, or servicing this equipment. Unless used properly, the machine can cause injury to operators or persons near it. In addition, improper use of the machine can cause damage to it or property near it. If in doubt, stop and obtain qualified help before proceeding.

Safety Precautions

Before installing, operating, or servicing this equipment, please read the following precautions carefully:

- This machine is equipped with moving belts. Do not place hands near the belts when they are moving as fingers may be pinched where belts enter the frame. We suggest the use of a roller-type exit conveyor or pack table for your cases. Always remove boxes after they clear the exit end of the machine.
- Use caution when near the tape heads or when threading tape. The tape cutting knives are very sharp, automatically operated, and linked to tape wipe down rollers.
- Always disconnect electrical power before attempting maintenance for any electrical or moving parts. Do not attempt to open or work on the electrical box, junction boxes, or other electrical components of the unit without first disconnecting power to the machine. Electrical shock hazard exists if power is not disconnected.
- Use only the specified power-supply cable. Do not use the power cable to pull or position the machine, as this will damage or break the cable.
- Do not bypass any factory-designed safety features such as guards, interlocks, switches, etc. Do not operate the machine if such modifications have been made.
- Do not attempt to operate the machine with loads that exceed the limits of use and operation in regards to weight and sizes, or with unstable loads that present a hazard of tipping or falling.
- This equipment is designed for indoor operation in a typical clean, dry factory environment. Do not operate the machine in any extremely wet or oily environment that may exceed operating specifications.

- Do not place hands, head, or any part of the body inside the confines of the machine unless the tape head mechanisms are securely fastened, and the electrical supply is shut off.
- To minimize the potential for personal injury, always be sure that the machine operators and others working on the machinery are properly trained in the correct usage of the equipment and properly instructed regarding safe operation.
- Never provide service or clear a box jam when machine is running. Always stop the machine and shut off power before servicing.
- Do not wear loose clothing such as ties, scarves, jewelry etc. Long hair should be pulled back and/or covered while operating this machine.

Explanation of Symbols



Caution sign or Safety Alert symbol. Indicates caution, be alert, Your safety is involved. Knowledge of safe operation is required. Caution indicates a hazardous situation which, if not avoided, could result in minor or moderate injury or damage to equipment or nearby property.

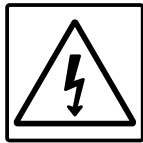

Electrical hazard. Indicates caution, electrical shock hazard. Allow only a trained electrician to open the door or cover of the electrical panel or box. Shut off electrical power before attempting to open or work on the electrical box, junction boxes or other electrical components of the unit.



Ground symbol. Indicates ground. Use Class-3 (lower than 1000) cable to ground to earth. Incomplete grounding may lead to electrical shock.



Caution! Hot surface. The surface indicated may become very hot during normal operation. Keep fingers, hands, and exposed skin away from hot surfaces to avoid burns. Allow hot surfaces to cool to ambient room temperature before performing service.



Caution! Moving parts. Moving parts can crush fingers or hand. Keep hands and fingers away from moving parts in area indicated to avoid injury.



Caution! Pinch point entanglement. Pinch point hazard exists in area indicated. Shut down the machine before performing maintenance, repair, or adjustment.



Caution! blade. Hazard exists for cutting fingers or hand. Keep hands and fingers away from sharp blades in area indicated to avoid injury.



Moisture hazard. Keep Equipment dry. This equipment is designed for indoor operation in a typical clean, dry factory environment, protected from rain and moisture. Do not operate the machine in any extremely wet or oily environment that may exceed operating specifications.



Eye protection. Wear eye protection. Use protective equipment whenever circumstances require or when required by regulation or law. Wear safety glasses when operating or servicing this machine.



Refer to this User Guide for important safety information and operating instructions to set up, operate, adjust, and maintain this Automatic Case Erector.



Warning symbol. Indicates a hazardous situation which, if not avoided could result in death or serious injury. A warning indicates a situation or condition potentially more severe than indicated by a caution message but not imminent as a danger message.

This symbol is associated with warnings for conditions as shown below.

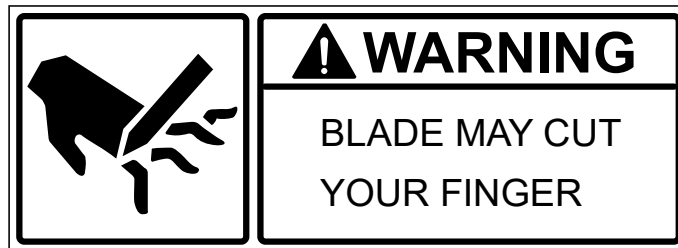

Introduction

The SB-2/3EX-Auto Case Taper is an automatic uniform side belt case taper designed to close all four top case flaps and seal the top and bottom of each case. The adjustable plow system allows adjustment for varying sizes of cases.

SB-2/3EX-Auto Case Taper Overview

The following illustration shows the SB-2/3EX Auto Case Taper with the operator side interlock safety gate door and window guard panels removed to allow identification of key functional features.

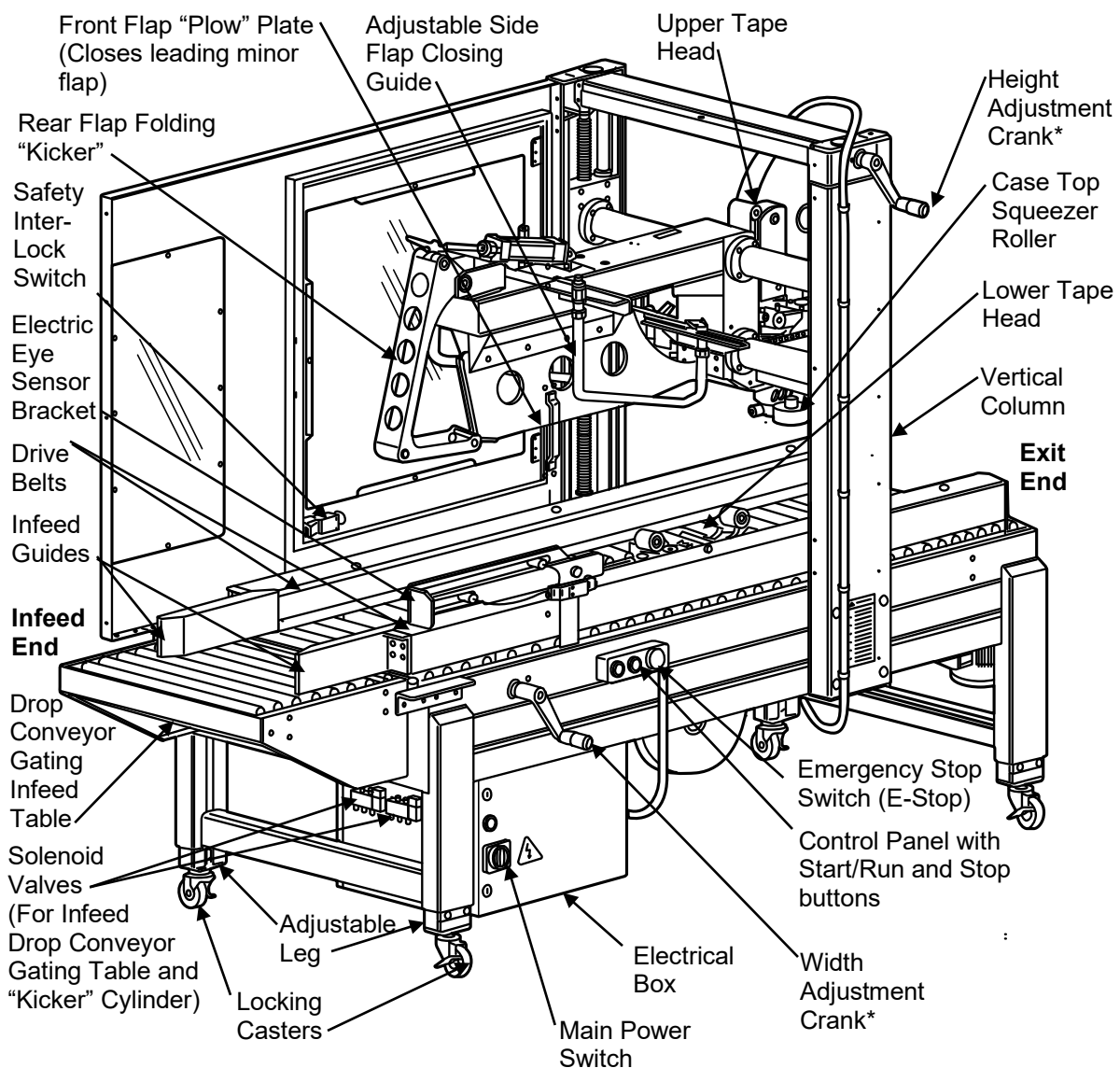

*Crank handles for height and width adjustments are removable and can be used on either side of the machine.

Specifications

SB-2EX AUTO Case Taper Specifications			
Sealer Type	Automatic uniform side belt, top and bottom case sealer		
Machinery Makeup	Industrial strength 12-gauge steel, powder coated for durability		
Belt Speed	75 feet/per minute		
Tape Speed	20 cases/per minute, depending on box size and operator efficiency		
Conveyor Height Adjustment	27" to 34.6"		
Box Specifications	Length	Width	Height
Minimum Box Size	5"	4.5"	4.5"
Maximum Box Size	24"	19.5"	19.5"
Tape Size	2" wide pressure sensitive tape up to 15" diameter rolls, optional 3" wide tape		
Tape Cartridge	Proven design requires no lubrication, designed for simple tape threading, removable for maintenance and interchangeable with top and bottom cartridges		
Air Requirements	85 PSI		
Electrical Requirements	110 VAC, 60Hz, 4.0A		
Agency Approvals	CE Certification		

SB-2/3 AUTO Case Taper Standard Features	
• Utilizes Eastey's EX tapehead	• Plug and go operation
• Powder-coated 12-gauge steel	• Adjustable side guide
• Industrial strength side belts	• Drop conveyor gating system
• Interlock safety gates for the kicker station	• Adjustable leg extensions
• Fast and easy box size change	• Low maintenance
• Accommodates wide case range	• Casters for transportation within plant

SB-2/3 AUTO Case Taper Optional Accessories	
3" Tape Head	Accepts 3" wide tape rolls
Exit Roller Table	Optional roller table bolts to machine exit end after taping system
Light Signal Stack	Optional 3-light signal stack to signal machine operation or attention

Electrical	
Belt Motor	0.18KVA
Machine Power Use	0.4KVA
Power Socket Need	0.5KVA

Machine Serial Number

The Machine Serial Number can be found on the identification label on the side of the base frame near the air in connection and air inlet filter and regulator.

The identification label displays the Model designator, Serial Number, Year of Manufacture, and Electrical Power Rating requirements.

Record the Serial Number and Year of Manufacture for future reference.

Note the electrical power characteristics indicated below the Model and Year. These specify the electrical power requirements for the case taping machine.

			
CASE SEALING MACHINE			
MODEL:	SB-2/3EX AUTO		
SERIAL:			
YEAR:			
DOC. NO.			
Volt	Hertz	Phase	Watt
230V	50Hz	1~	0.45kW
Ampere	Short Circuit Rating		Weight
2.0A	20A		310 kg

Typical Applications

Eastey SB-2/3EX-AUTO Automatic Case Taping Machine

This case taping machine is intended for operation to automatically close top flaps and seal top and bottom flaps of cases by applying OPP (oriented polypropylene) tape.

Do NOT use the Automatic Case Taping Machine to seal the following product types:

- Explosive Products
- Flammable Products
- Hazardous Products
- Pharmaceuticals
- Agri-Foodstuffs
- Wet Products
- Products that are heavier or larger than allowed by the machine specifications.

Do not operate the machine in any extremely wet or oily environment that may exceed operating specifications. This equipment is designed for indoor operation in a typical clean, dry factory environment protected from rain and moisture.

Dimensions

Dimensions shown in inches (and centimeters).

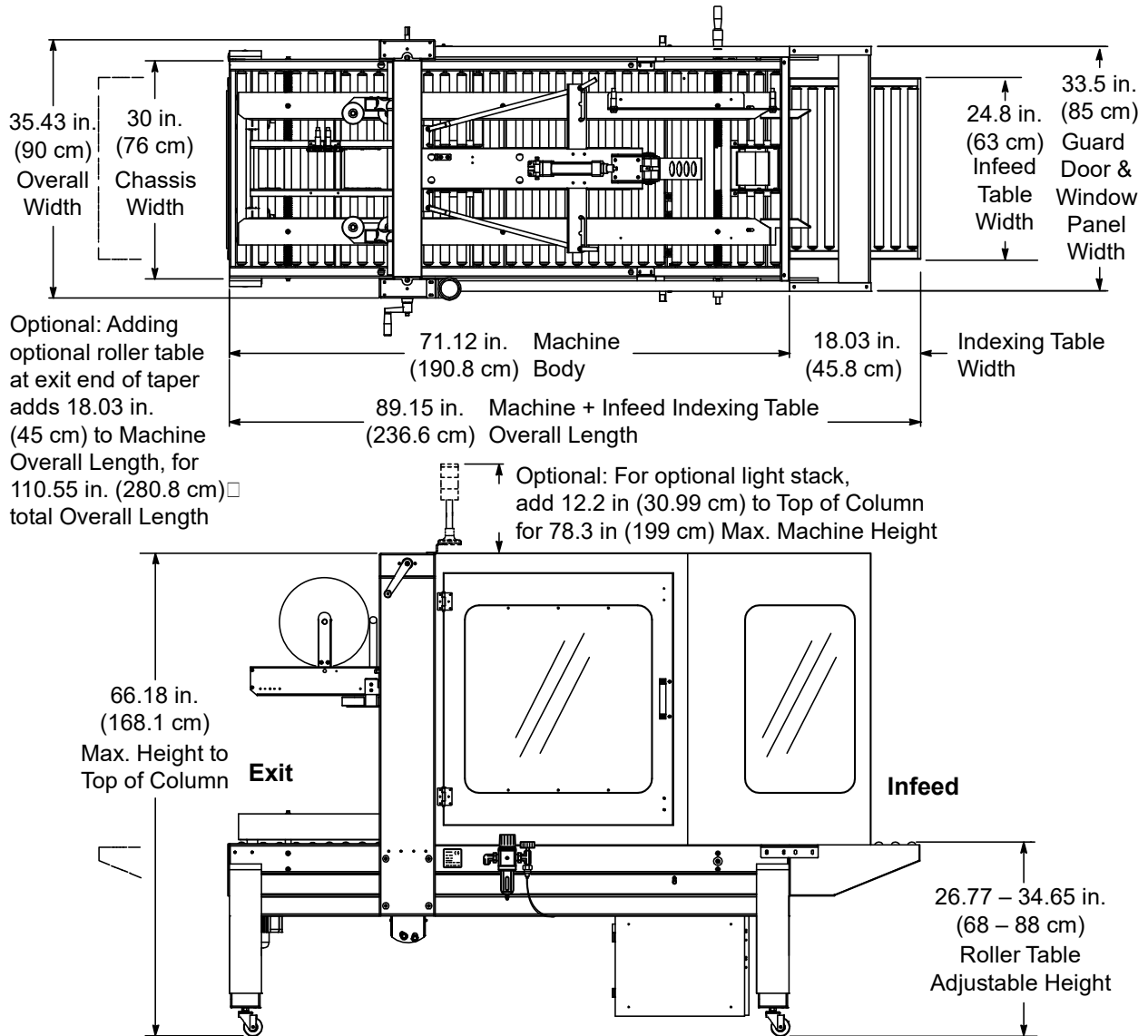

Installation

Carefully remove the outer protective outer shipping materials. Avoid damaging the machine body.

Remove the shipping bolts that secure the case taper to the shipping pallet. Lift the case taper off the pallet.

CAUTION! The SB-2/3EX-Automatic Case Taper is very heavy and will require a forklift, floor crane, or several people to move safely off the shipping pallet. Use proper equipment when lifting the case taper and ensure the case taper is secure and will not shift while being moved or during height adjustment or installation of locking casters.

Four locking casters are provided and optionally may be installed onto the four adjustable support legs. To install casters, thread one caster into the bottom of each leg.

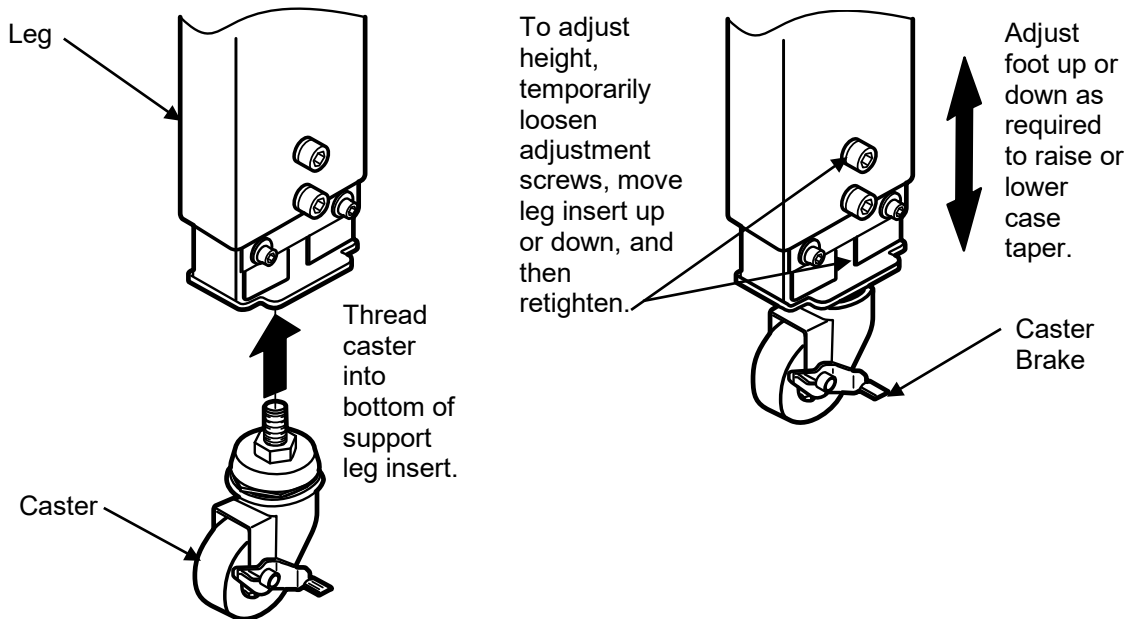

CAUTION! Raise the case taper off the floor to install the casters. Use proper equipment when lifting the case taper. Ensure the case taper is secure and will not shift while installing the casters or adjusting the height.

To adjust the leg height, loosen the screws on each leg and slide the insert up or down as required and then retighten the screws at the required height. When the case taper has been moved to its suitable location, use the caster brake to secure the case taper from rolling.

Location Requirements

Move the case taper to the desired location. To lift or move the case taper without casters installed, you will need to use a pallet jack or forklift to lift and move it. If you have installed the casters, release the brake lever on each of the locking casters to move the taper easily over a smooth flat surface. Re-engage caster brake levers when the case taper has been moved to its location.

When installing the case taper please be aware of the following considerations:

1. The mounting surface is flat and level.
2. Conveyor or packing table height.
3. Alignment with packaging line.

When the case taper is positioned in the operating location you will need access to:

1. The Main Power Switch and Control Panel, with Start/Run and Stop buttons and E-Stop.
2. Height and width adjustments.
3. Both upper and lower tape cartridges for tape loading.
4. Air in and supply hose connection.

A packing table may be provided at the infeed end where the packer can fill boxes and position the flaps while feeding the boxes into the machine for closing and sealing. It is also convenient to have a pack table at the exit end of the taper.

It is essential that the table and conveyor be at the machine bed height.

The machine should be placed on a flat, level floor so that it does not rock or move. When placed for operation, securely lock the locking casters. We recommend that the machine be securely locked in place when in operation.

Connect the air supply hose to the filter/regulator assembly on the side of the machine.

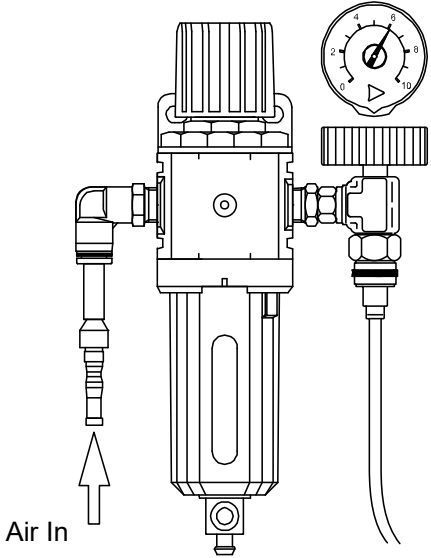
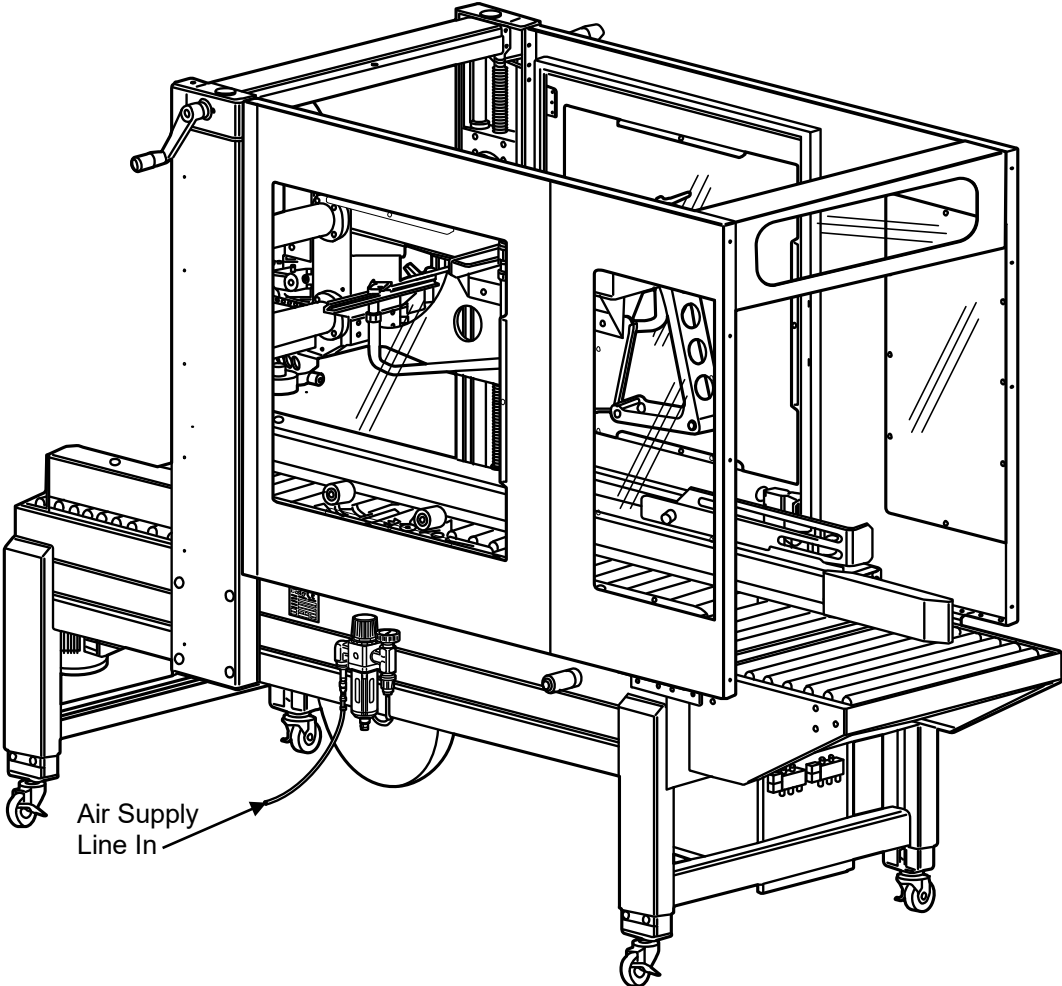

Optional Exit Roller Table

An optional exit roller table is available for the case taper that is similar to the entrance indexing table, less the drop conveyor indexing mechanics. If the exit roller table has not been installed from the supplier or has been removed for shipping, install it as follows.

1. Temporarily loosen socket head cap screws at the locations shown in the following illustration.

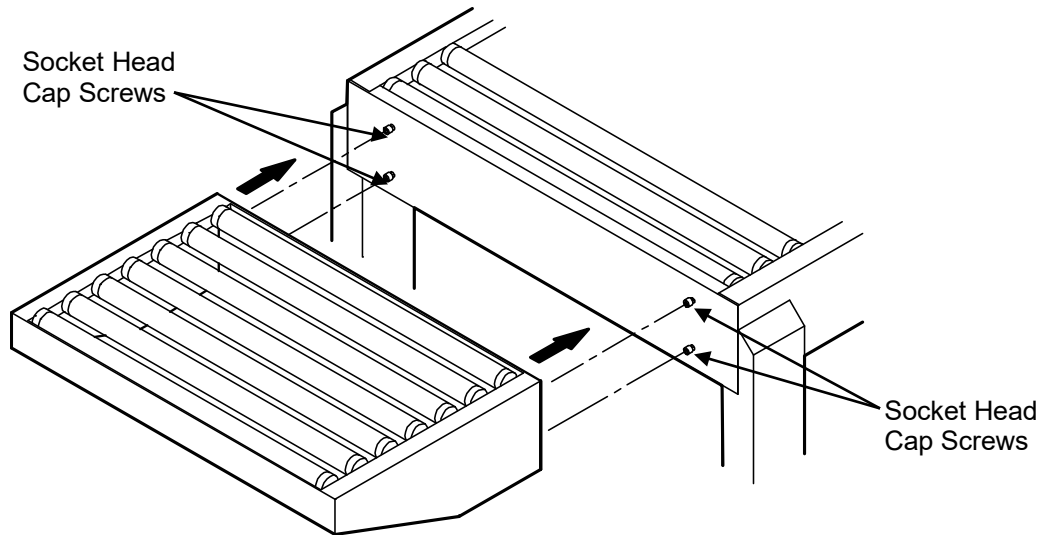

2. Align the keyhole slots in the table flanges with the loosened cap screw heads and position the end table so rollers are level with the case taper rollers.
3. Re-tighten cap screws loosened in the first step to secure table.

Next Steps

Follow instructions in the Operation section for instructions to load the tape cartridges in the upper and lower tape heads.

If tape heads have not been loaded with tape, load the upper and lower tape heads with tape. (One roll each; follow instructions provided in the Tape Cartridge User Guide.)

Refer to the Adjustments section for instructions to make necessary height and width adjustments that must be made for operation of the box taper.

Refer to the Operation section for instructions to power up, operate, and shut down the machine.

Operation

Loading the Tape Cartridges

Turn the main power switch to “Off” and disconnect the power.

CAUTION! To avoid personal injury, remove the tape cartridge before loading tape.

When handling the tape cartridge be careful to avoid contact with the tape cutting blade.

After the taping cartridge has been removed push the tape roll onto the tape core assembly.

NOTE: Make sure the tape roll is pushed all the way on the spindle assembly.

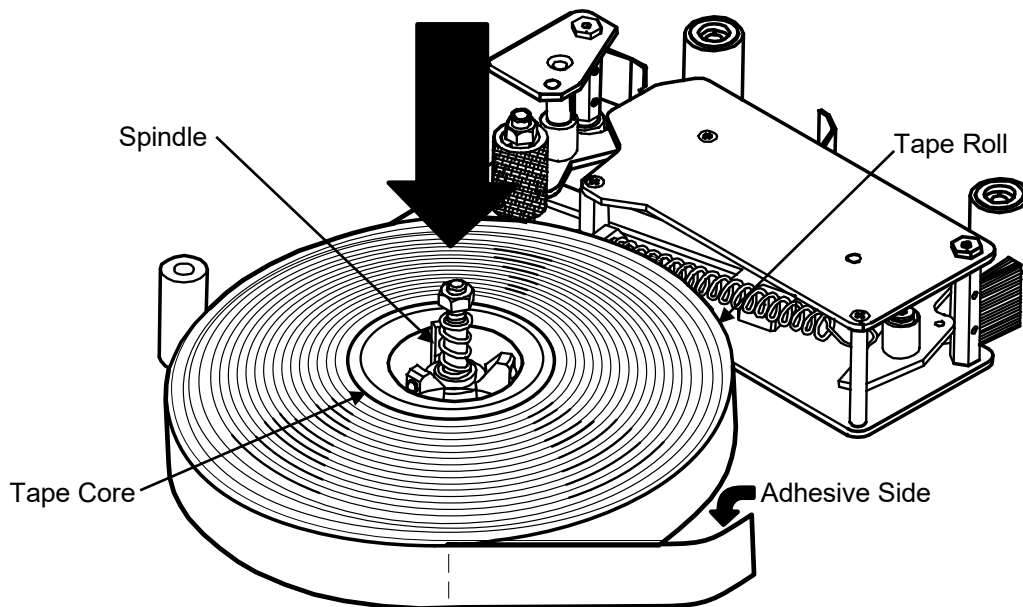

Check Tension

Check the tape for correct tension.

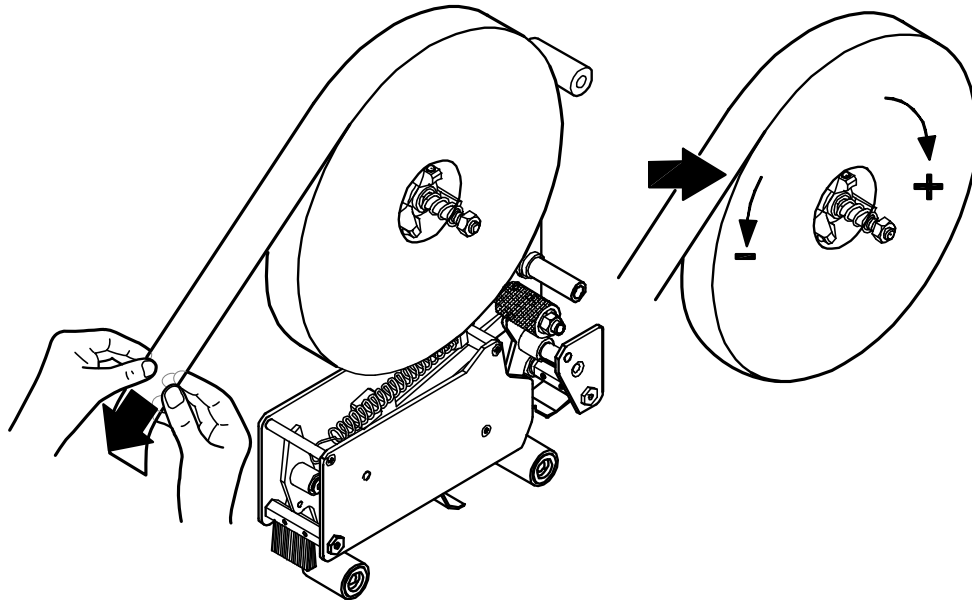

Tighten or loosen the tape core holder to adjust tension.

Thread Tape

Carefully thread the new tape through the rollers in the tape head as shown in the applicable diagram in the Tape Head User Guide provided with the tape head.

For convenience, diagrams for threading tape in the Eastey-EX Tape Head and EZ-EX Tape Head are provided on the following page. Follow the diagram that applies for your tape head, depending on the tape head model and position on the taper.

Eastez-EX Tape Head

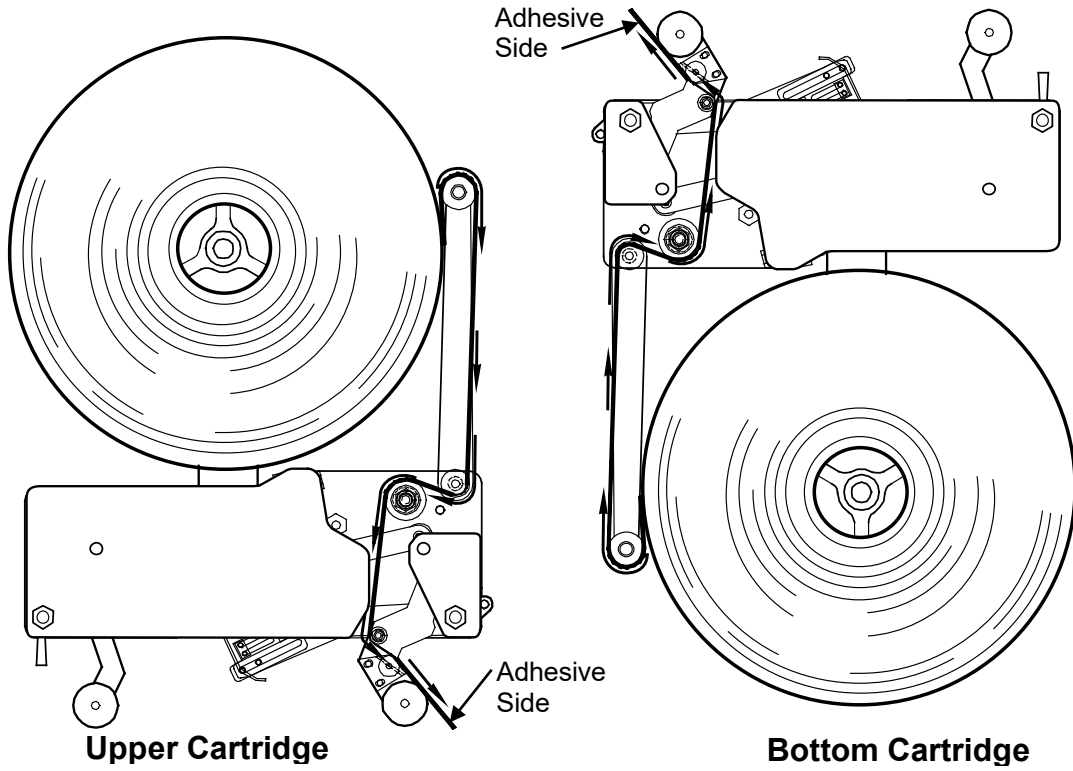

EZ-EX Tape Head

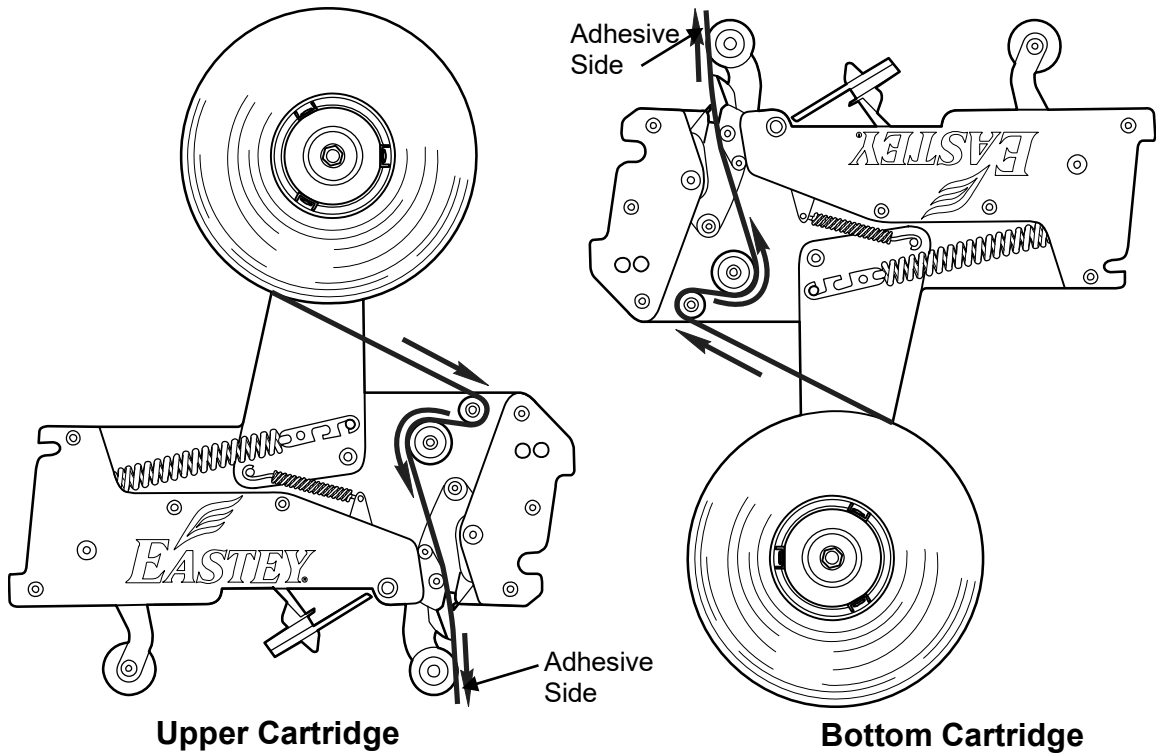

Center Tape — Eastey-EX Tape Head only

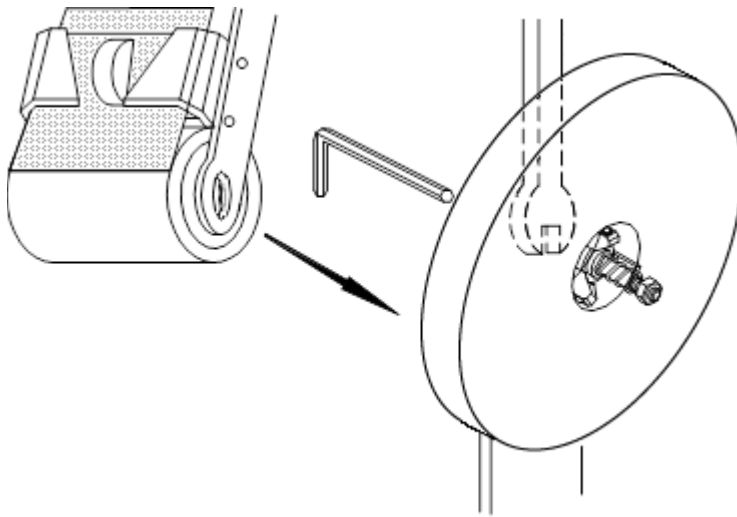

Make sure the tape is centered on all the rollers.

There are several rollers in the tape cartridge where the tape alignment should be checked to verify the tape stays on center as it is being dispensed.

Return the tape cartridge to the operation position.

Main Spring Adjustment

When setting tension for the rollers, consider the amount of pressure on the box flaps required to make the seal. Cases completely filled to the top with product may require more pressure on top and bottom seams when applying tape than partially-filled cases, where excessive pressure could possibly crush the case.

For sealing light weight boxes, decrease the main spring tension. For heavier boxes, increase the main spring tension.

Both Eastey-EX and EZ-EX tapeheads have a main spring, which may require tension adjustment for the particular application for which you will be using the case taper.

For quick reference and convenience, basic information for adjusting main spring tension for the Eastey-EX Tape Head and EZ-EX Tape Head is provided on the following page. For more information about setting the tape head tension, refer to the User Guide provided with the tape heads that are being used in the case taper.

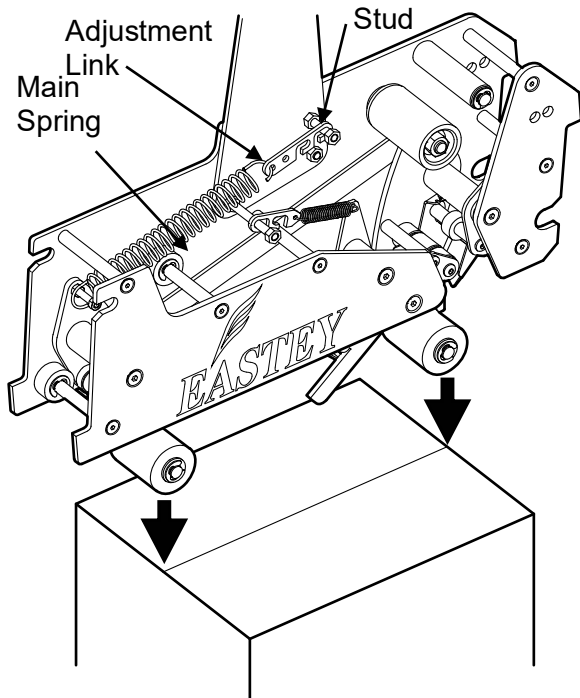

Eastey EZ-EX Main Spring Adjustment

For the Eastey-EZ tape head, there is an adjustment link at the end of the main spring that links the spring to the stud post.

Spring tension is determined by which part of the adjustment link is hooked onto the stud post on the connecting arm, and by which hole in the adjustment link the main spring is hooked onto.

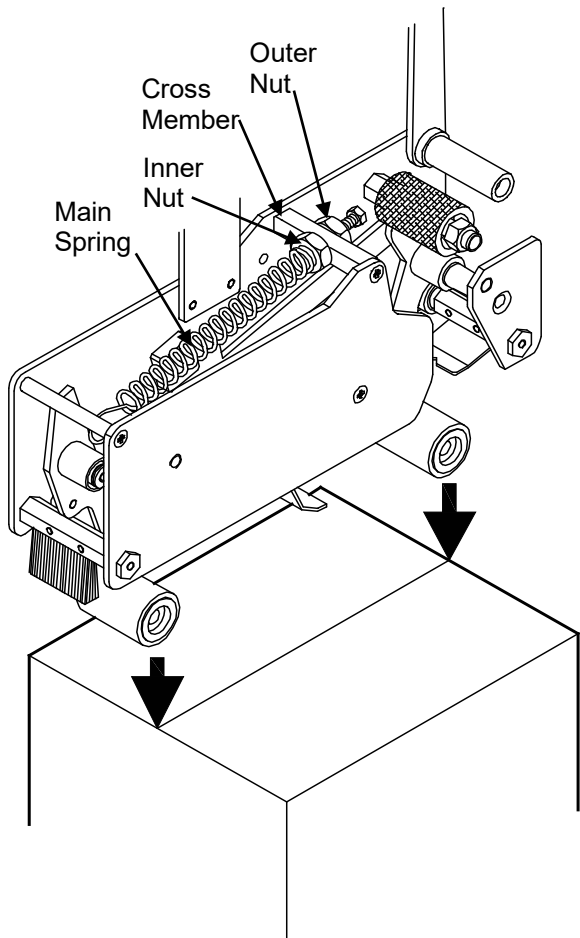
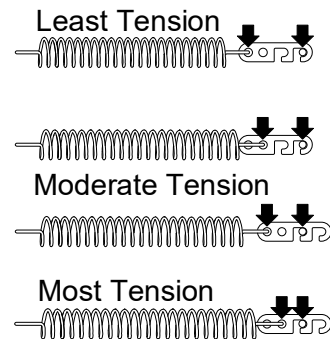

Eastey-EZ Main Spring Adjustment

For the EZ-EX tape head, there are two adjustment nuts, one to each side of the top crossmember where the threaded rod of the adjustable end of the main spring passes through the crossmember.

The adjustment nuts are used together to set the main spring to the required tension and to secure the spring at the set tension.

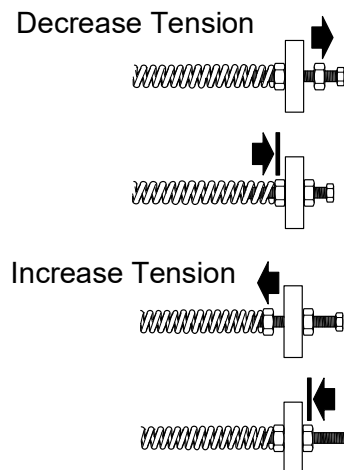

Power and Control Panel

Plug the power supply cord into a properly wired and grounded outlet.

CAUTION! When the power is turned on be aware of moving parts and belts

The main power switch and control panel are located on the operator's side of the automatic case taper. The main power switch is located on the door of the electrical panel. The power indicator light is located above the main power switch. The control panel is located on the same side of the machine above the main electrical panel.

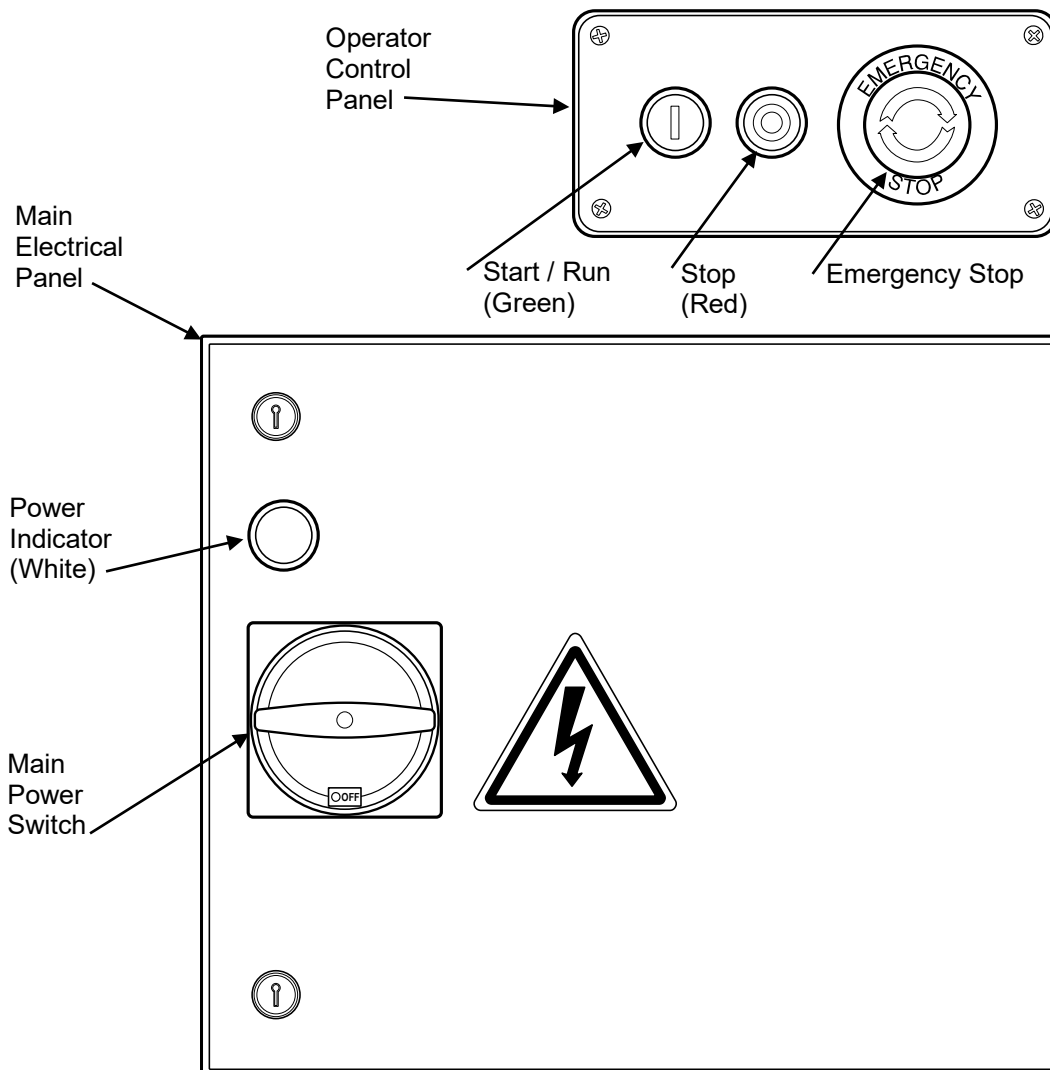

NOTE: The door of the electrical panel must be closed securely for the main power switch to be operational.

Power Switch Operation

Turn the Power Switch one quarter turn clockwise to turn on power. Turn the Power Switch one quarter turn counterclockwise to turn power off.

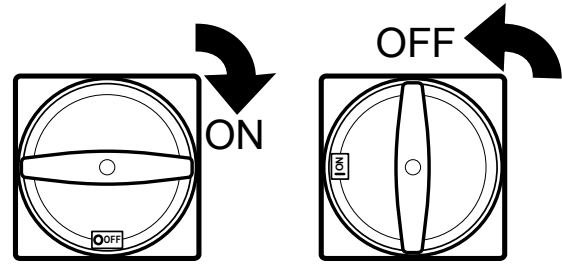

When the main power switch is in the ON position the power indicator lamp will be illuminated.

Control Panel Operation

Press Start button on the control panel to begin automatic taper operation.

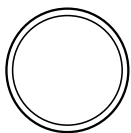
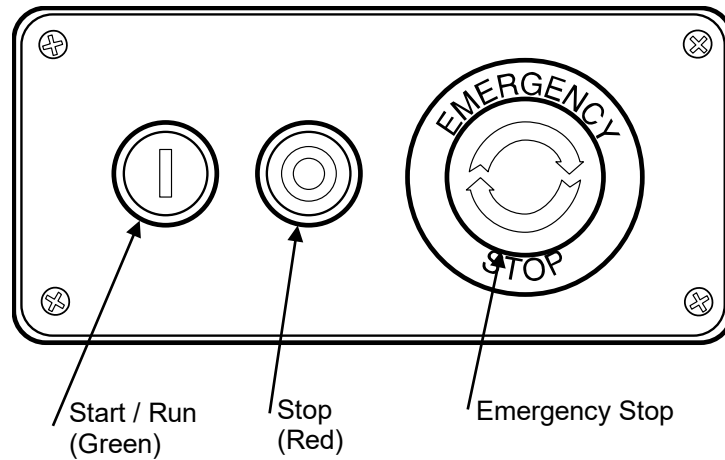

Power Indicator Lamp (White)

- On when case taper is in operation.
- Off when case taper is not in operation.



Start / Run Button (Green)

Press the Start button to start motors and belts.

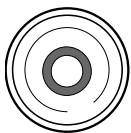

Stop Button (Red)

Press the Stop button to stop motors and belts.



Emergency Stop Button (Red with Yellow label)

- Press the red Emergency Stop button for emergency stop.
- To reset the Emergency Stop button once the emergency condition has been cleared and it is safe to operate the machine again, press the Emergency Stop button in while turning it approximately a quarter-turn in the direction of the arrow.

Adjustments

Air Pressure unit

The air pressure is pre-set at the factory to 80 PSI. The air pressure can be changed up or down for specific requirements. Make air pressure setting changes only in small increments.

Inspect the unit periodically to make sure the drain system is functional and properly lubricated.

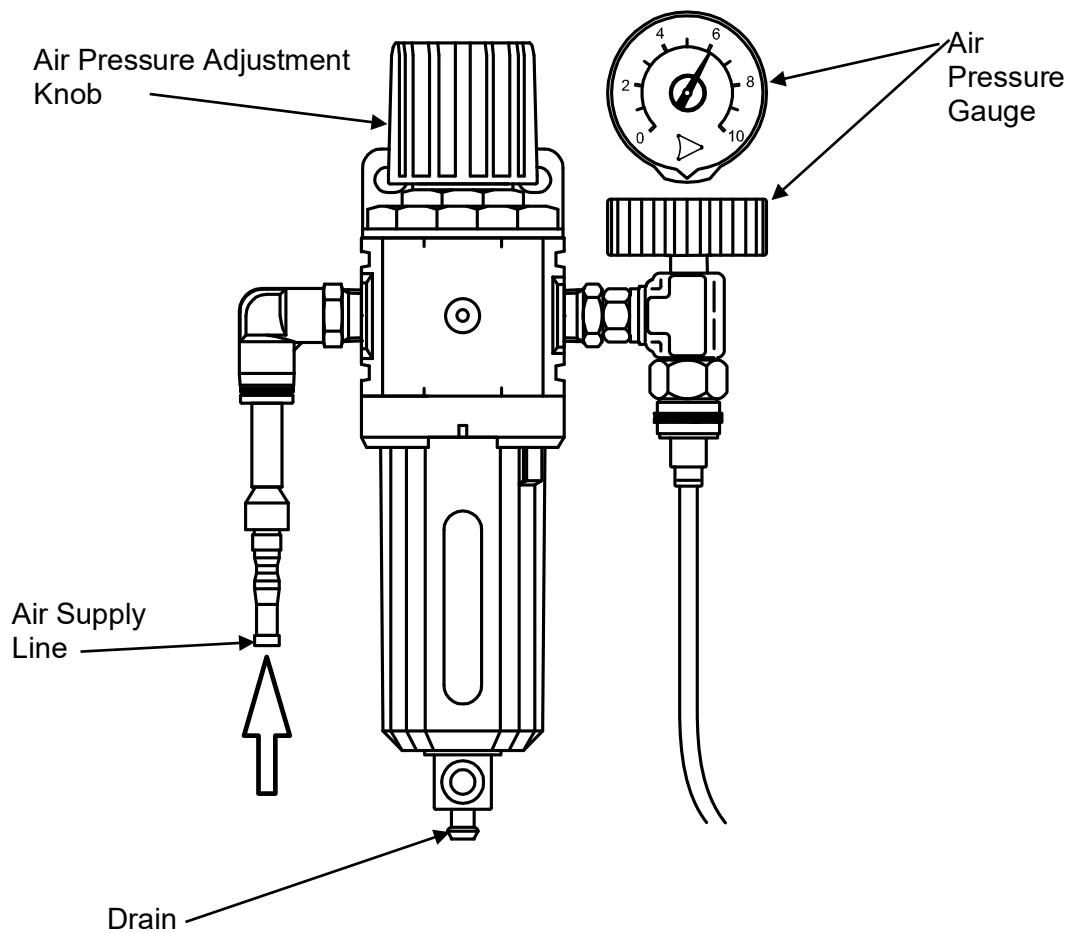

Height and Width Adjustment

With the power off, place an appropriate size case in the Case Sealer.

Use the drive belt width adjustment crank to set the drive belt width to the correct box width.

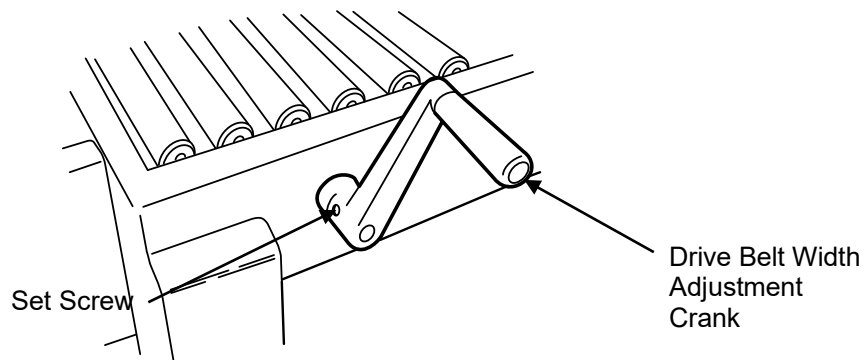

Use the height adjustment crank to set the upper tape head to the correct box height.

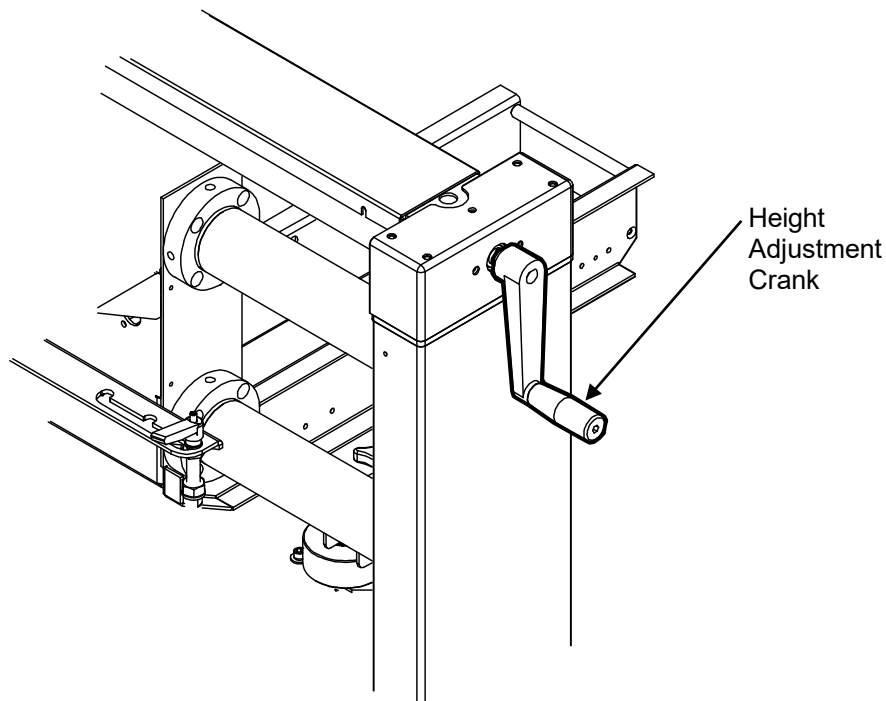

The height and width cranks can be mounted on either side of the machine by loosening the set screw and removing the crank. Mount the crank on the opposite side and re-tighten the set screw.

Top Squeezer Roller Width Adjustment

Loosen the locking knobs on the top squeezer alignment rollers to set the top width to the correct box width and re-tighten the locking knobs. This will ensure the box stays centered.

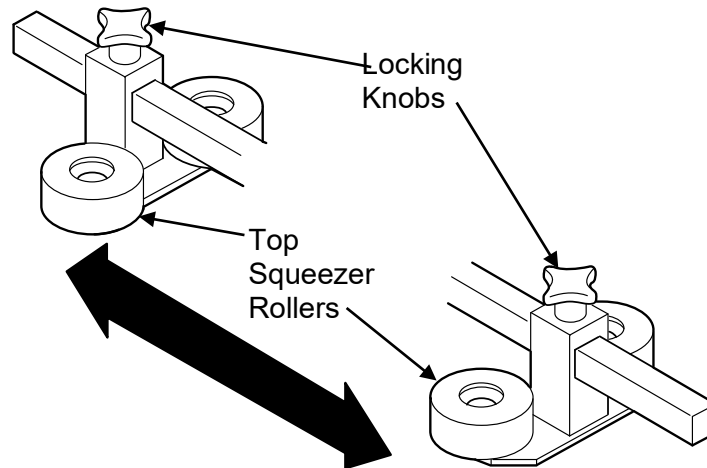

Flap Closing Guide Adjustment

When front cardboard flap touches the front flap folder, the front flap will be folded to 60° initially, and then folded flat as the box moves under the front flap folder.

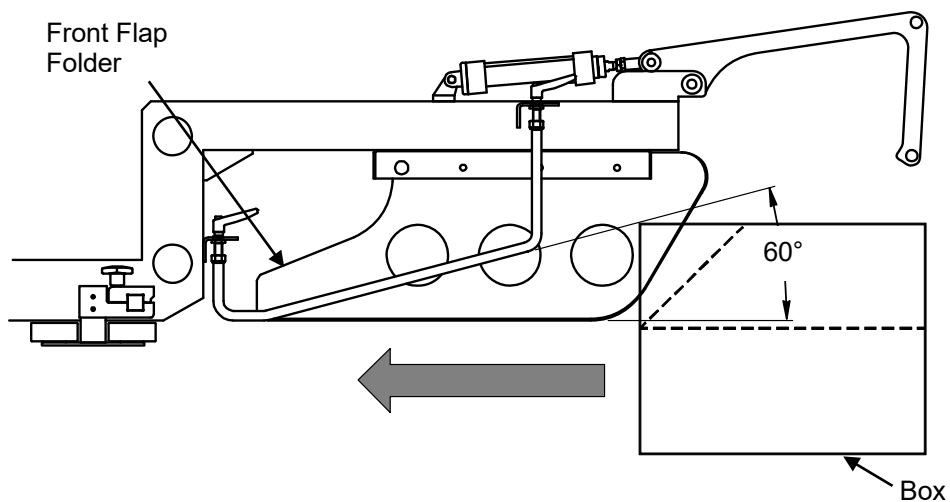

Side View

Side flaps will be closed as the box moves forward under the two closing arms. The ideal angle of the two closing bars is 30° apart in horizontal plane (width), and at 15° incline from horizontal. The closing arms are set to an incline angle of 15° , but: arms are moveable and adjustable in both the height and width axes.

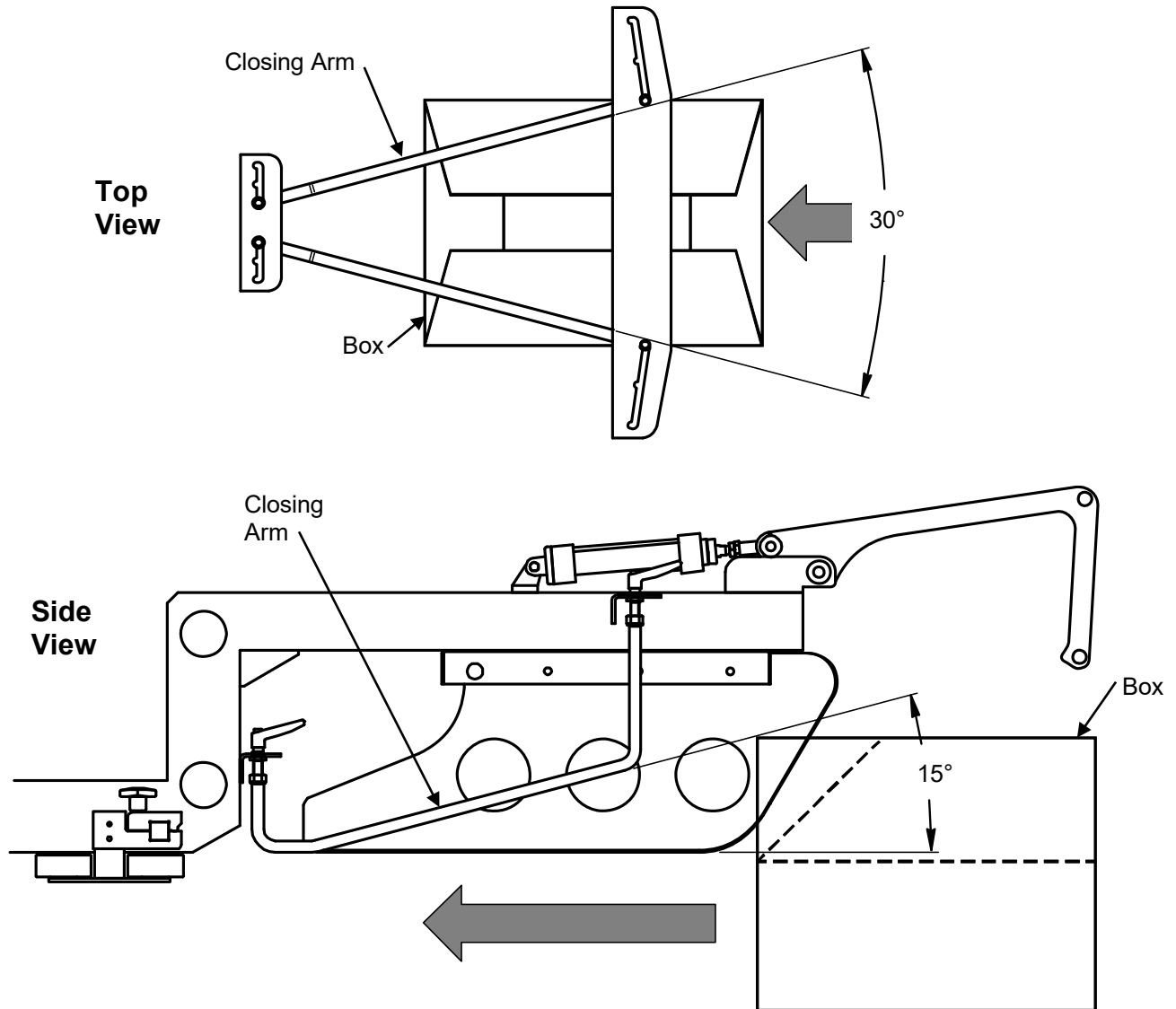

Rear Flap Closer Speed Adjustment

NOTE: Flow controls for extension and retraction of the rear flap closer are pre-set at the factory and should not require adjustment. If you need to change the speed of the rear flap closer, make changes in small increments. Adding too much pressure can cause the closer arm to go down too fast and too hard.

There are two small air flow control knobs on the cylinder that allow speed adjustment of the rear flap closing arm. The knob at the cylinder base adjusts the down speed and the knob at the cylinder rod end controls the retraction speed. To reduce the speed of cylinder action, turn the knob clockwise to restrict airflow. To increase the speed of cylinder action, turn the knob counterclockwise to allow increased airflow.

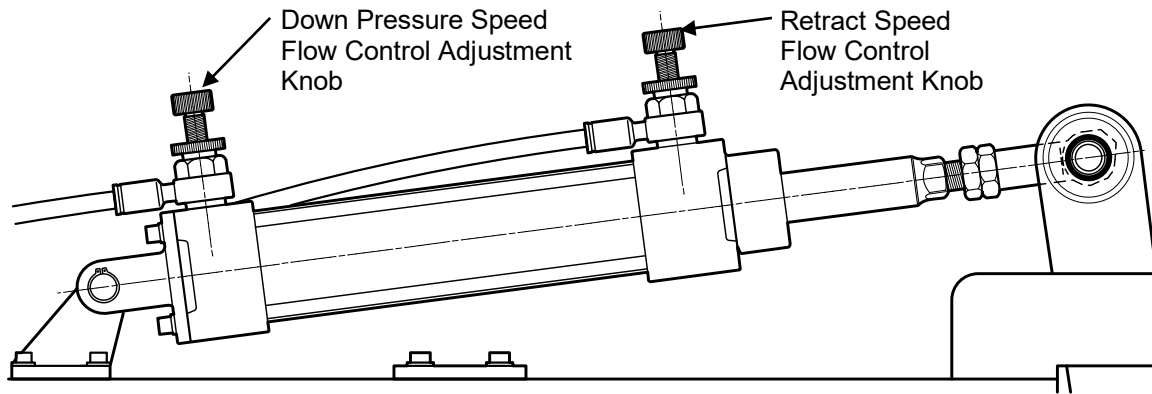

Belt Adjustment

It is not necessary to remove the drive belt cover to adjust the drive belt. To adjust the belt, use an allen wrench and loosen the socket head cap screw that locks the idler position. Adjust the belt to a suitable tension by turning the adjustment screw with a phillips screwdriver. Re-tighten the socket head cap screw when belt is at required tension.

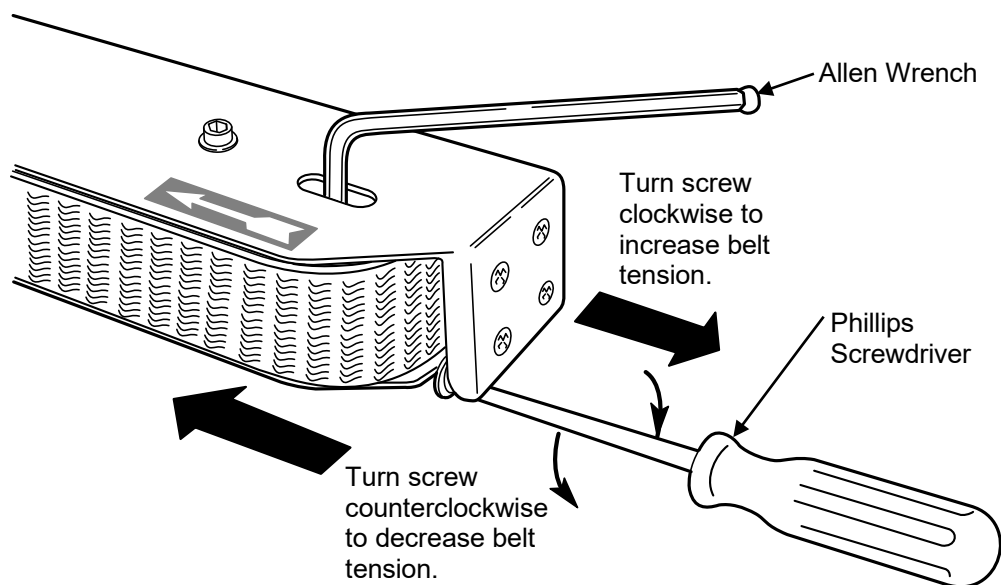
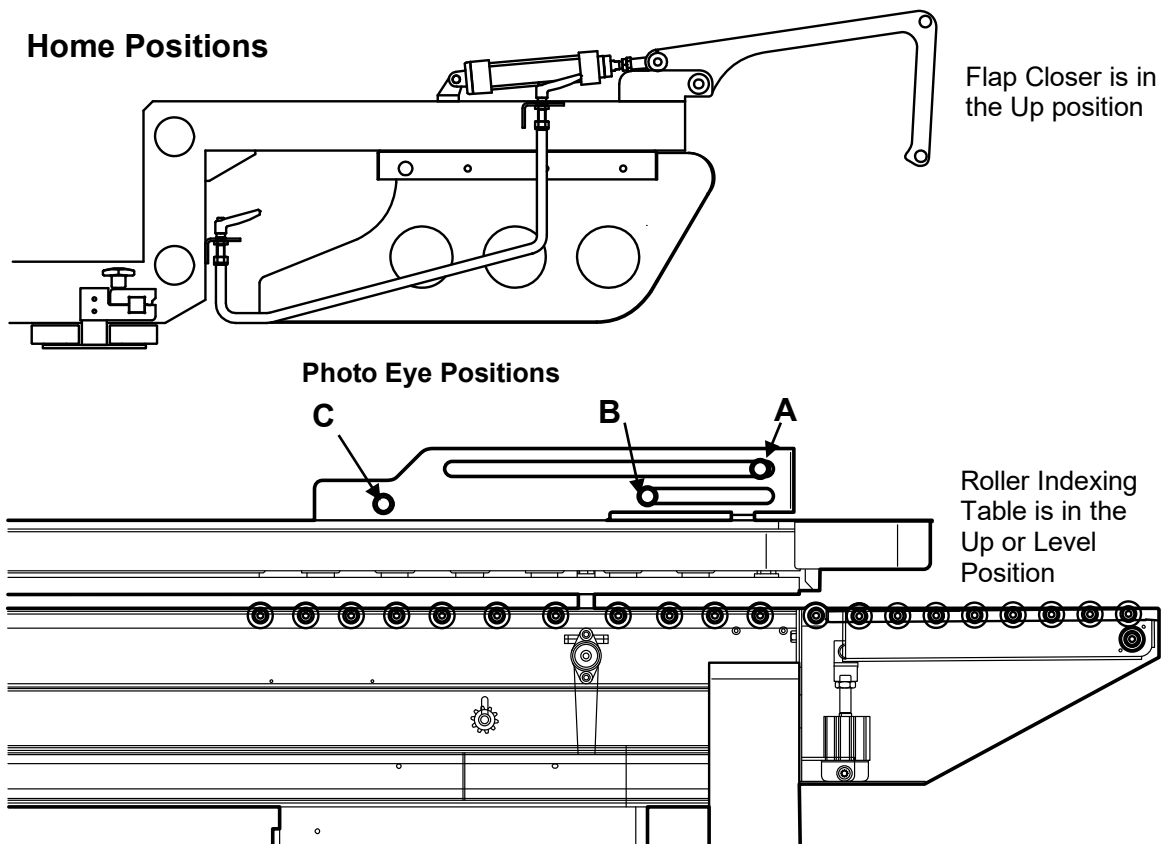

Photo Eye Location Adjustment for Drop Conveyor Gating and Rear Top Flap Closer Kicker Timing

To know how to adjust the location of the infeed area photo eye sensors for your application, it is important to understand how they function to signal actions to control the timing of the drop conveyor infeed roller table and of the rear flap closer kicker.

The drop conveyor gating infeed roller table ensures that only one case enters the auto case taper at a time and prevents any subsequent case from entering the flap-closing area of the taper while the current case is being closed.

The home position for both the drop conveyor and the rear flap closer is for the drop conveyor to be in level, or up position and for the rear flap closer to be in the up position.



When the first photo eye sensor (A) at the infeed is blocked by the case entering, it signals for the infeed roller table to lower. The dropped roller table effectively creates a blocking step to prevent any following case to move forward into the flap-folding area while the current case is being processed.

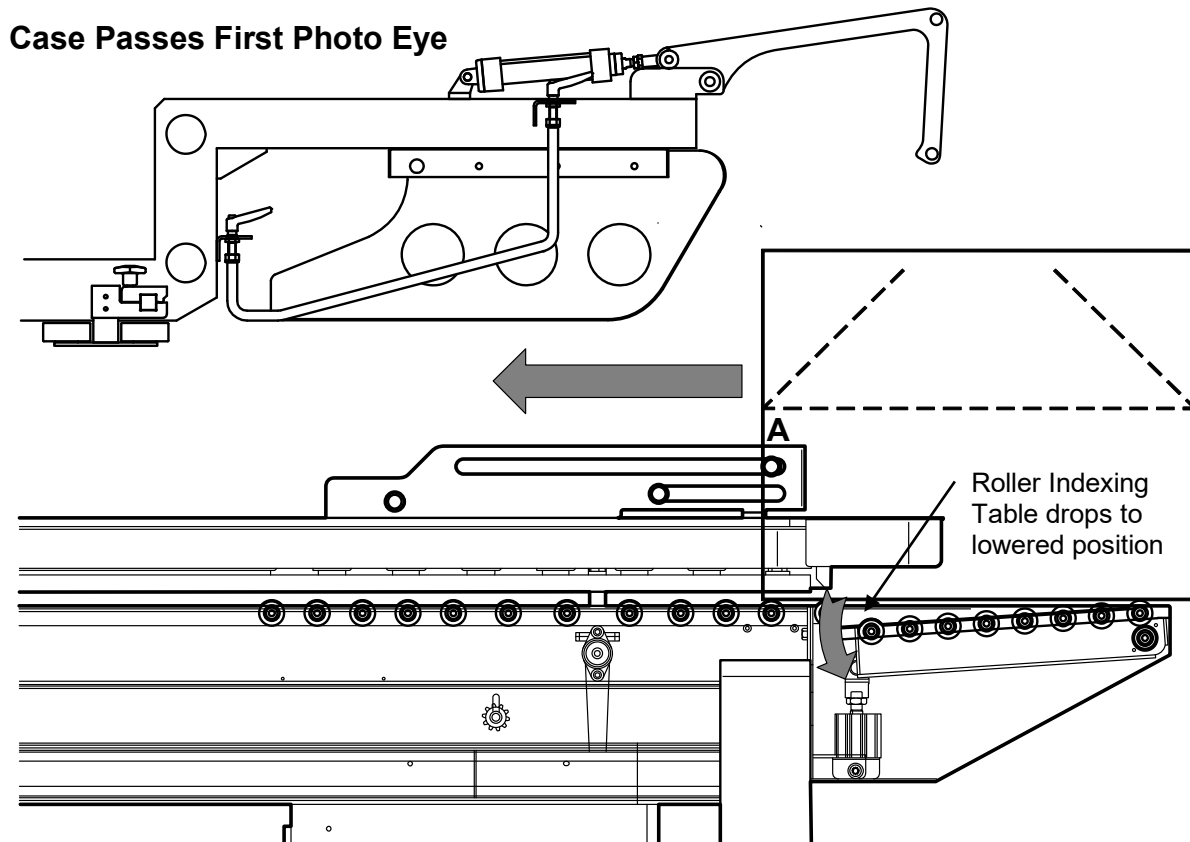

The case will move into the area of the second photo eye sensor (B). Where sensor A is activated by the case blocking the sensor, sensor B is activated as soon as the case clears sensor B. The moment the case clears sensor B, it signals the rear flap closer kicker to activate to fold down the rear flap.

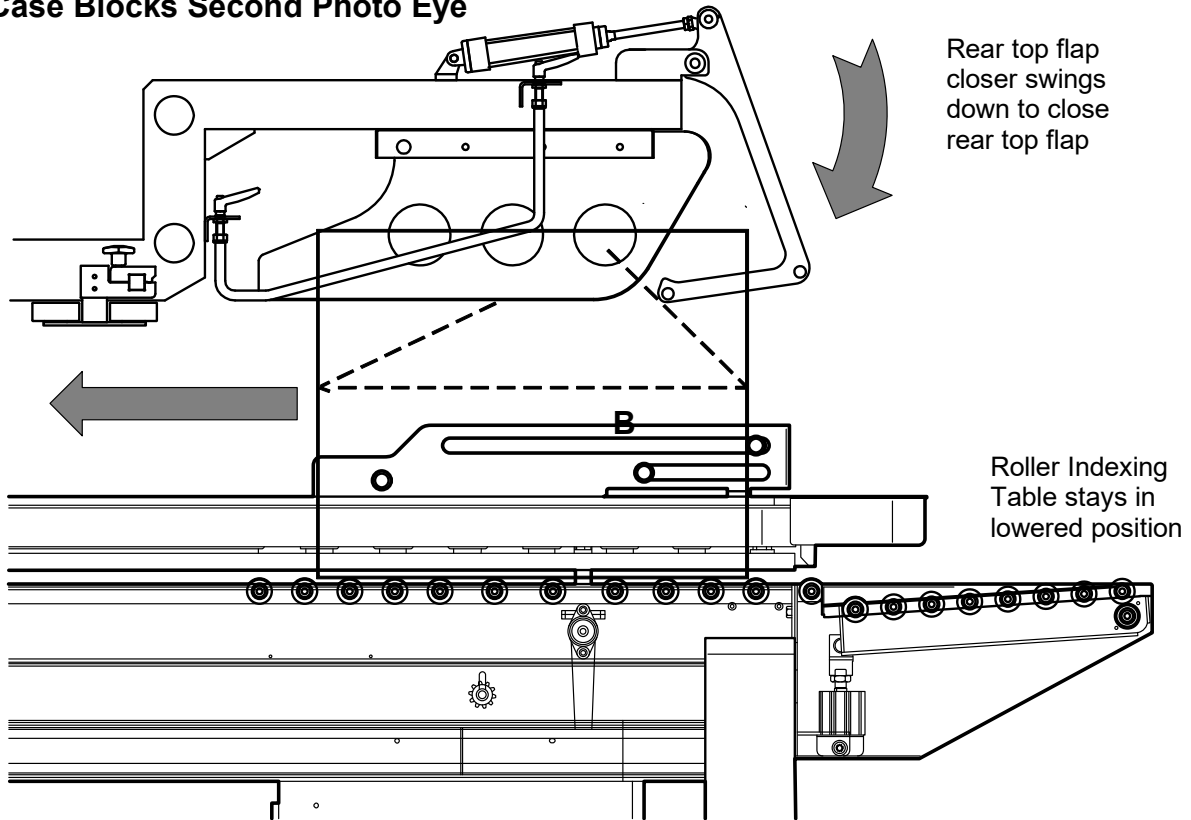
Case Blocks Second Photo Eye

When the box passes and clears the final photo eye sensor, sensor C on the bracket, this signals for the infeed roller table to rise back up level with the rollers, and it signals for the rear top flap closer to swing back up to its home position, and the Auto Case Taper is ready for the next case.

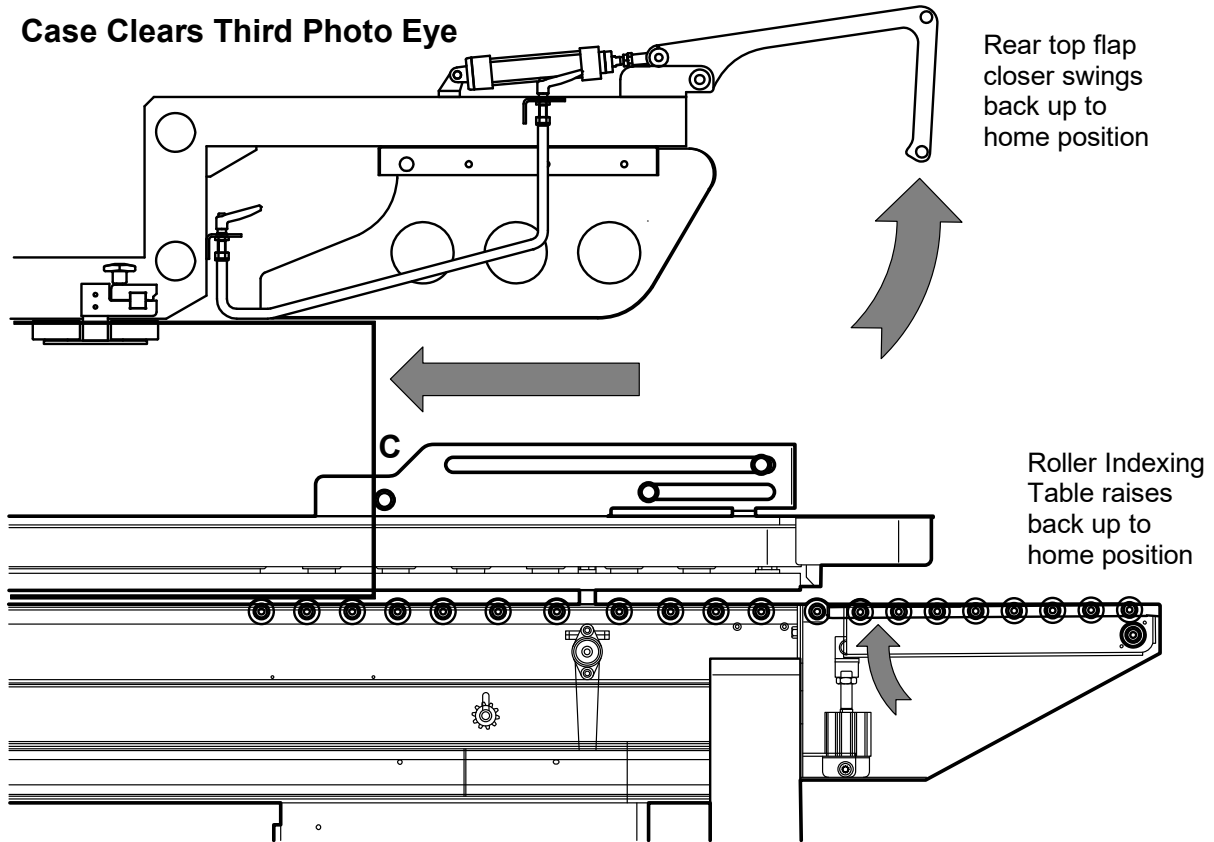

It is recommended to set the first photo eye A so that the roller indexing table will drop down when 2/3 of the case length has been transported onto the main taper rollers and the trailing 1/3 of the case length is remaining on the indexing table.

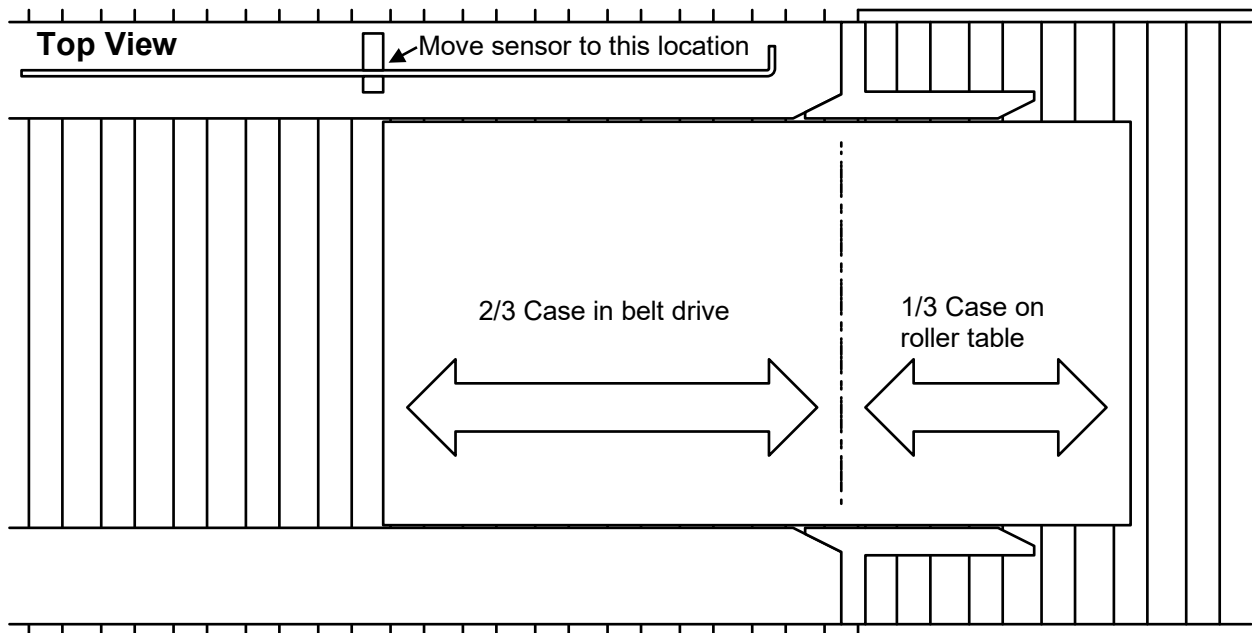

Machine Body Height Adjustment

To adjust the leg height, loosen the screws on each leg and slide the insert up or down. When the leg is at the desired height, retighten the adjustment screws to secure the leg height.

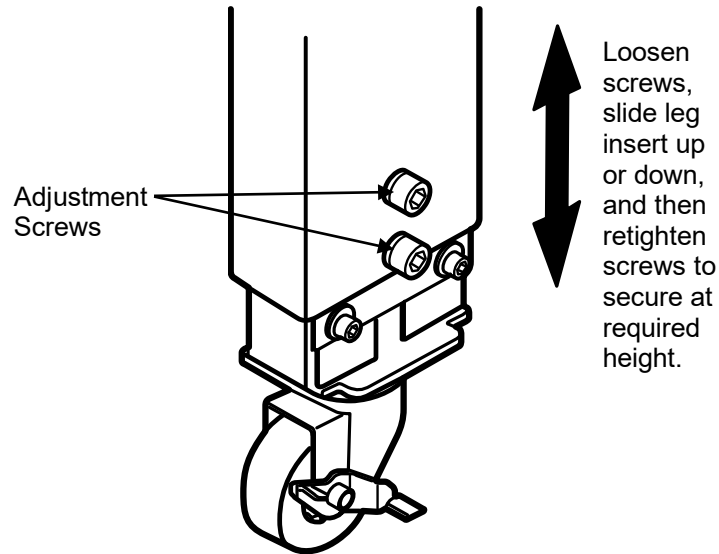

CAUTION! Ensure the case taper is secure and will not shift while adjusting leg height.

Tape Head Adjustment — Refer to Tape Head User Guide.

Refer to instructions in the Tape Head User Guide that is provided with the tape head for instructions regarding adjustment information for the tape head.

Maintenance

The SB-2/3EX-Automatic Industrial Case Taping System will provide many hours of maintenance free operation. There are a few items that may require attention from time to time.

Rollers

Make sure rollers stay clean and grease free. If you should have to clean the rollers simply wipe them down with a clean lint free cloth. If a more thorough cleaning is necessary, wipe the rollers down with a mild detergent and water and let dry. **Never use harsh or abrasive cleaners or chemical agents when cleaning the rollers.**

Cutting Knives

Occasionally inspect the cutting knives to ensure they are clean and free of adhesive residue. Make sure the cutting knife is sharp by inspecting cuts in the tape. Cuts should be straight and neat. If the quality of cuts is eroding, the knife blade is dull and should be replaced.

Changing Knife Blades — Refer to Tape Head User Guide

Turn off and unplug the taper. It is not necessary to remove either tape head to change the blade. Refer to the Tape Head User Guide provided with the tape head for instructions for changing the knife blades.

CAUTION! Always be aware of the cutting edges while replacing the knife blades. Handle the knife blades carefully.

Troubleshooting

Problem	POSSIBILITIES	Solution
If machine is not operating.	The air pressure may not be sufficient.	Adjust the air Pressure.
If the air cylinder on the flap closing system does not work.	Kinked or pinched hoses and/or wiring.	Reposition the hoses & wiring.
If the indexing gate (stopper), doesn't operate.	a) Bent, pinched, or twisted hoses & wiring. b) Defective infeed or exit photo eyes sensors.	(a) Re-position hoses & wiring. (b) Adjust the position of photo eye or replace with a new one.
If the machine cannot tape boxes.	The side belts are not correctly adjusted for the box size.	Use the width adjustment crank to adjust the side belt width.
Start Button Indicators	START button flashes 1 time.	Normal operation.
	START button flashes 2 times.	The motor is overloaded.
	START button flashes 3 times.	STOP button is on or wiring may be disconnected. Check wiring.
	START button does not flash.	(a) Turn on the power, power indication light will be on. (b) Release the E-STOP.

Parts List

Electrical

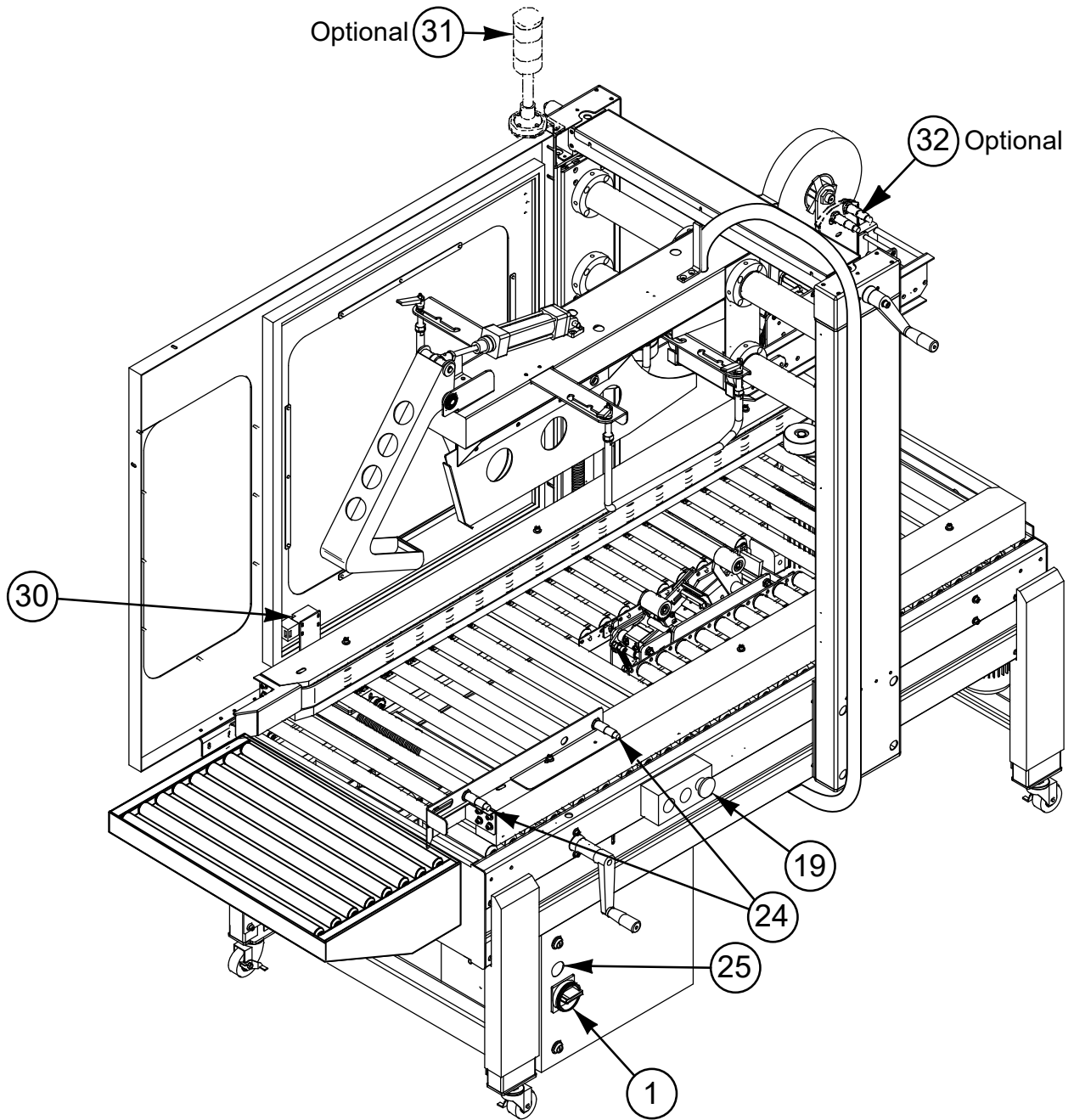

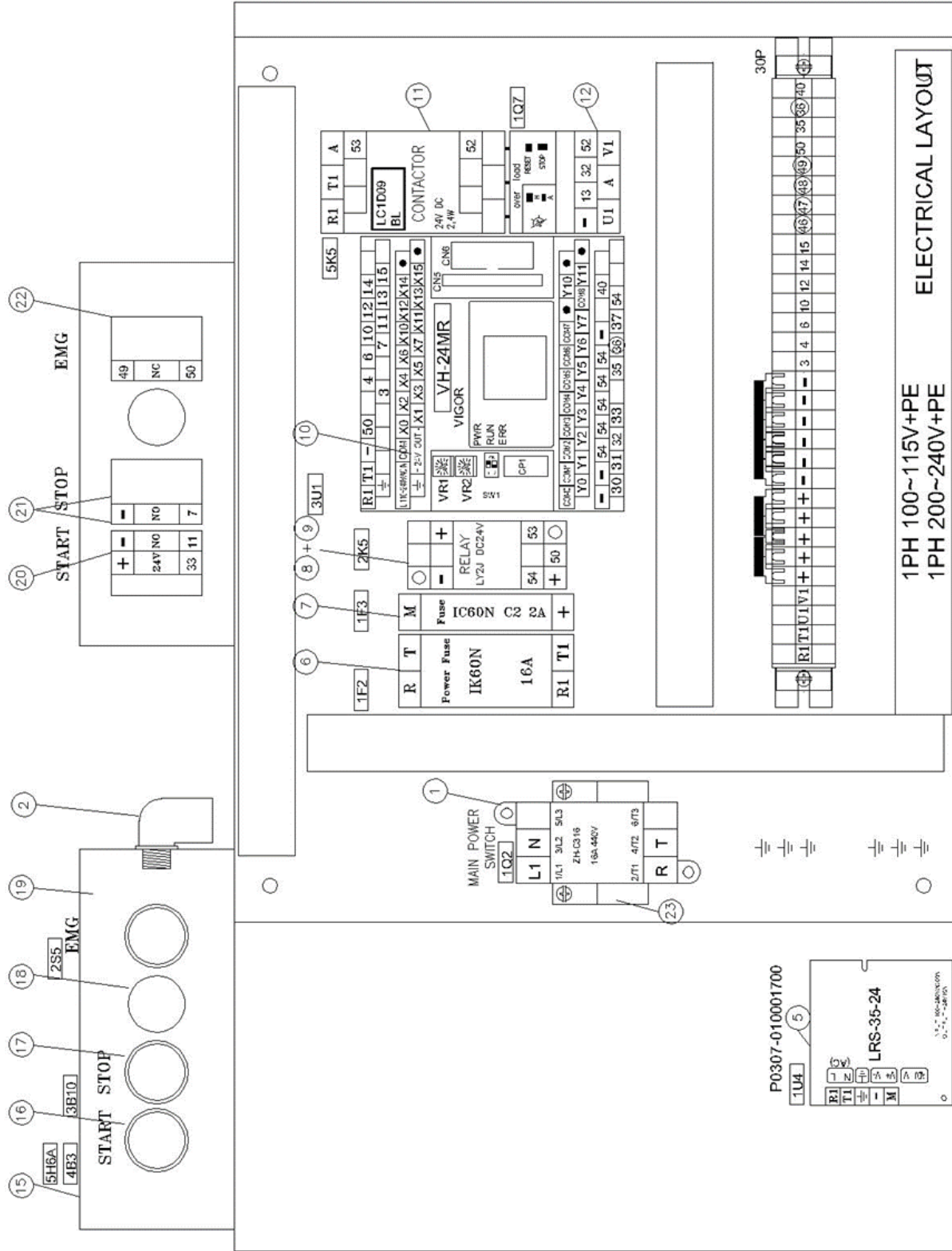

1PH 100~115V+PE
1PH 200~240V+PE

ELECTRICAL LAYOUT

40 Parts Lists

ITEM	PART NO.	DESCRIPTION	REFERENCE	Q'TY
1	5005501	SEPARATED POWER ON/OFF	P0311-020000700	1
2	5001756	1/2"90°CONNECTOR (BVWD-G027GT)	7066C064	2
4	5005502	TBD		1
5	5005503	POWER SUPPLY LRS-35-24	P0307-010001700	1
6	5005504	CIRCUIT BREAKER IK60N2PC16A	P0305-010001200	1
7	5030708	CIRCUIT BREAKER IC60N1PC2A	P0305-010001500	1
8	5001917	RELAY LY2 DC24V	7270R301	1
8	5005505	FIXING PLATE PYCA1	727100010	2
9	5001918	RELAY SEAT LY2	7270B301	1
10	5005506	PLC VIGOR VH-24MR	73002002	1
11	5005275	CONTACTOR LC1-D09BL (DC24V)	72600001	1
12	5001760	THERMAL OVERLOAD RELAY 110V, 4~6A	71570002-02	1
12	5001760-V1	THERMAL OVERLOAD RELAY 220V, 2.5~4A	71570003-02	1
12	5005507	THERMAL OVERLOAD RELAY LR3D06 1-1.6A)400V,50HZ	P0306-040000400	1
13	5005508	TERMINAL POST 30P	P0304-010007300	1
15	5001874	ON/OFF SWITCH BOX XALD04	71840002	1
16	5001824	AUTO RUN GREEN LAMP COVER	7150AW01	1
17	5001978	BUTTON RED ZB5-AL432	7155AL01	1
18	5005279	SLEEVE ?22	7030HP22	1
19	5005509	EMG.SWITCH	P0313-010005400	1
20	5001824-S	AUTO RUN GREEN LAMP ZB5-AW061	7150AW02	1
20	5004027	LED LAMP DL1-LED241	7150LD01/109A011	1
21	5001908	(START)(STOP)BUTTON SEAT CONTACTOR(NOx1) ZB5-AZ101	7158AZ01	2
22	5005510	EMG. BUTTON SEAT CONTACTOR NCx1	7158AZ03	1
23	5005280	FIXING PLATE TBR-F	71000001	2
24	5001706	PHOTO SENSOR CDR-10X	7360CD01	3
25	5005053	White LAMP XA2BVB1C	7150BVB1/109A010	1
26	5001706-1	PHOTO SENSOR CDR-10X-M12 (option)	7360CD02	4
27	5005511	PHOTO SENSOR CONTACTOR LINE (option)	7360CD02-01	4
28	5005512	SELECTOR SWITCH XA2ED33 (option)	P0313-010006100	1

ITEM	PART NO.	DESCRIPTION	REFERENCE	Q'TY
30	5002208	SAFETY SWITCH TZ-93BPG	7365P003	2
30-1	5005513	SAFETY SWITCH KEY TZ93-K3	7365K003	2
31	5005404	ALARM LIGHT TOWER (option)	KA0000410	1
31-1	5005398	ILLUMINATED units XVMC33 (Green) (option)	KA0200050	1
31-2	5005399	ILLUMINATED units XVMC34 (Red) (option)	KA0200060	1
31-3	5005400	ILLUMINATED units XVMC35 (Orange) (option)	KA0200070	1
31-4	5005401	BASE unit XVM-C29B (option)	KA0200080	1
31-5	5005402	Fixing bases XVM-Z02 (option)	KA0200090	1
31-6	5005403	LEDs LC1-EDBS5W/24V (option)	KA0200100	3

Pneumatic Parts

ITEM	PART NO.	DESCRIPTION	REFERENCE	Q'TY
1	5001820	AIR F.R.L UNITS (MAFR300L-8A-D)	P0405-0000110	1
2	5001820-1	CONNECTOR (PL8-02)	81060105	7
3	5001995	MPP-20 CONNETCOR	81060100	1
4	5001820-2	PRESSURE GAUGE	81040001-1	1
5	5001734	SOLENOID VALVE	81090001	3
6	5002101	BRASS SILENCER	81100101	5
7	5001996	CONNECTOR (PC8-02)	81060120	4
8	5005283	(1/4") SLEEVE	81150001	1
9	5005284	(1/8") SLEEVE	81150002	2
10	5005515	CONNECTOR (PE8)	P0401-0007100	1
11	5002100	CONNECTOR (JSC8-01A)	81060127	2
12	5005516	ISO CYLINDER (MCQV2-11-40-100)	P0402-0001400	1
13	5005517	ISO CYLINDER MCJQ-11-40-25	P0402-0007400	1
14	5001573	CONNECTOR JSC8-02A	81060133	2
15	5005285	CONNECTOR, PLF8-02	81060146	1
16	5005240	CONNECTOR, PL6-M5	81060109	1
17	5005518	CONNECTOR, PG8-6	P0401-0011800	1
18	5001834	CONNECTOR, PC-1/4	81096001	1
19	5030770	CONNECTOR, PY8	P0401-0011700	1
20	5005235	CONNECTOR, BCN-0201	81060202	1
21	5005243	CONNECTOR, BTF-001	81060203	1
22	5005250	CONNECTOR, PC8-1,	81060113	1

Side Belts

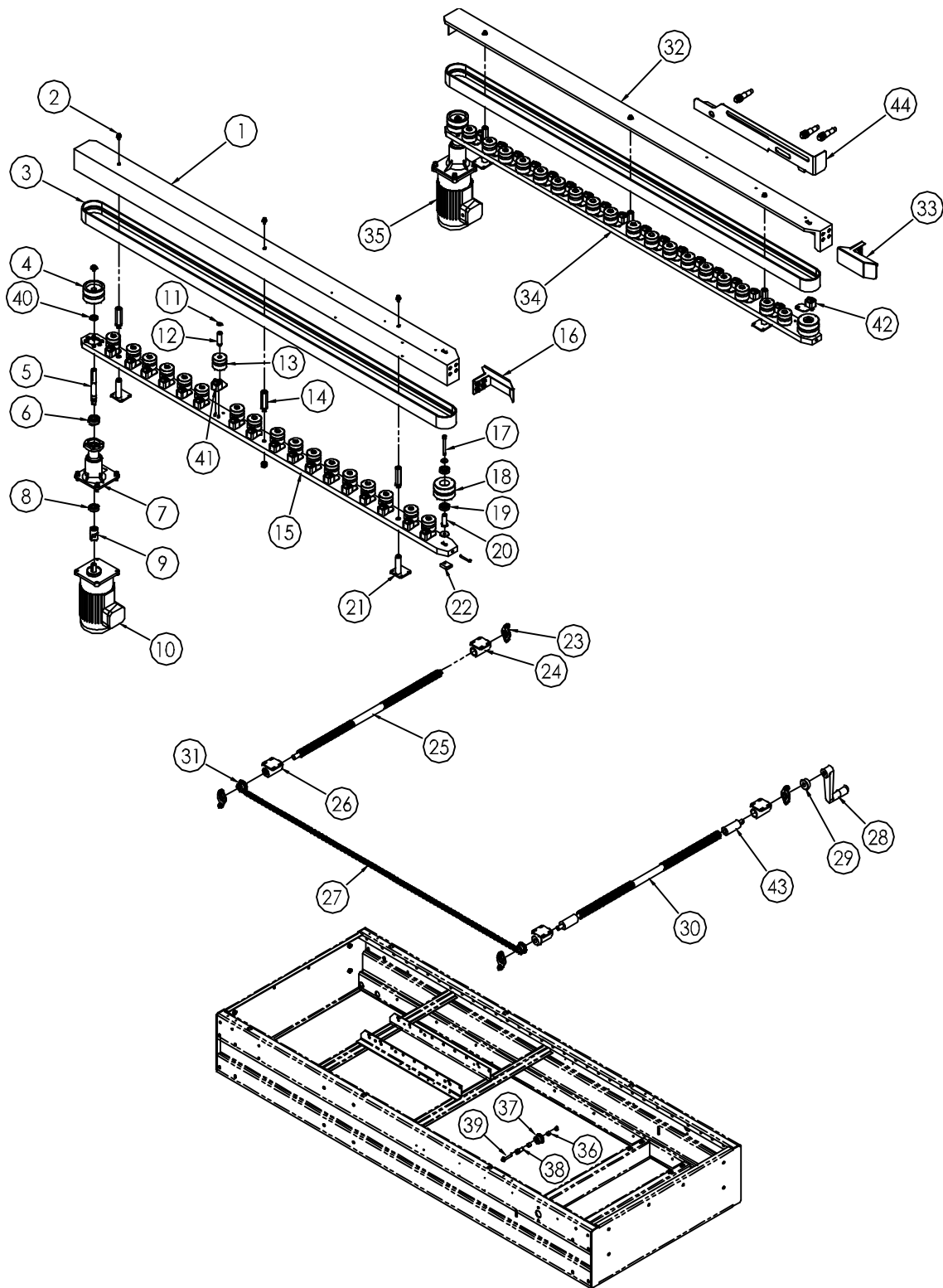

44 Parts Lists

ITEM	PART NO.	DESCRIPTION	REFERENCE	Q'TY
1	5005520	BELT COVER		1
2	5030480	SCREW M6*12L	P1101-0906012AN	6
3	5005521	BELT	P0902-0010200	1
4	5005522	PULLEY DRIVER	P0703-0003400	2
5	5005523	MOTOR SHAFT	P02-008020A	2
6	5030855	BEARING 6203	P1104-0262032RS0	2
7	5030853	MOTOR SEAT	P02-0080300	2
8	5001700	BEARING 6003ZZ	P1104-026003ZZ0	2
9	5030858	UNIVERSAL JOINT	P1121-0000100	2
10	5005524	MOTOR 110V/60HZ, T18:1	745111L1	1
10	5001714-V1-60	MOTOR 220V/60HZ, T18:1	745122L1	1
10	5001714-V1-50	MOTOR 220V/50HZ, T15:1	745122L2	1
10	5001714-V2-50	MOTOR 240V/50HZ, T15:1	745124L2	1
10	5001714-V3-50	MOTOR 380V/50HZ, T15:1	745138L1	1
10	5005290	MOTOR 400V/50HZ, T15:1	745140L1	1
11	5005525	RING S-14	P1105-0114B	36
12	5005526	PULLEY SHAFT	P02-0079600	36
13	5005527	PLASTIC PULLEY	P0703-0003300	36
14	5005528	SPECIAL SCREW	P02-0085300	6
15	5005529	SUPPORT COLUMN		1
16	5005530	GUIDE PLATE		1
17	5030872	SCREW M8*70L	P1101-0508070AN	2
18	5005531	PULLEY FOLLOWER	P0703-0003200	2
19	5001700	BEARING 6003ZZ	P1104-026003ZZ0	4
20	5005532	PULLEY SHAFT	P02-0079500	2
21	5005533	SUPPORT SHAFT	P02-0284500	4
22	5005534	ADJUSTMLNT BLOCK	P02-0080100	2
23	5005535	SHAFT SEAT		4
24	5005536	SPINDLE SUPPORT	P02-0079700	2
25	5005537	SPINDLE WIDTH ADJUSTMENT	P02-0079300	1
26	5005538	SPINDLE SUPPORT	P02-0079800	2

ITEM	PART NO.	DESCRIPTION	REFERENCE	Q'TY
27	5005539	CHAIN #35x328	P0901-0001600	1
28	5002202	HANDLE CRANK ARM	P1112-000060A	1
29	5031109	HANDLE RING	P06-0022600	2
30	5002153	SPINDLE WIDTH ADJUSTMENT	P02-007920A	1
31	5005540	CHAIN SPPOCKET 12T	P0702-0004800	2
32	5005541	BELT COVER		1
33	5005542	GUIDE PLATE		1
34	5005543	SUPPORT COLUMN		1
35	5005544	MOTOR 110V/60HZ, T18:1	745111R1	1
35	5001713-V1-60	MOTOR 220V/60HZ, T18:1	745122R1	1
35	5001713-V1-60	MOTOR 220V/50HZ, T15:1	745122R2	1
35	5001713-V2-50	MOTOR 240V/50HZ, T15:1	745124R2	1
35	5001713-V3-50	MOTOR 380V/50HZ, T15:1	745138R1	1
36	5030854	BUSHING	P02-0080400	2
37	5031212	CHAIN WHEEL	P0702-0004700	1
38	5005545	CHAIN WHEEL SHAFT	P02-0079000	1
39	5005546	SCREW M6x25L	P1101-1006025AZ	1
40	5005547	WASH	P06-0046200	4
41	5005548	CUSHION ASSEMBLY (L)	P02-0282500	15
42	5005549	CUSHION ASSEMBLY (R)	P02-0282600	15
43	5002156	SHAFT	P02-007940A	1
44	5005550	SENSOR SEAT		1

Vertical Column with Height Adjustment

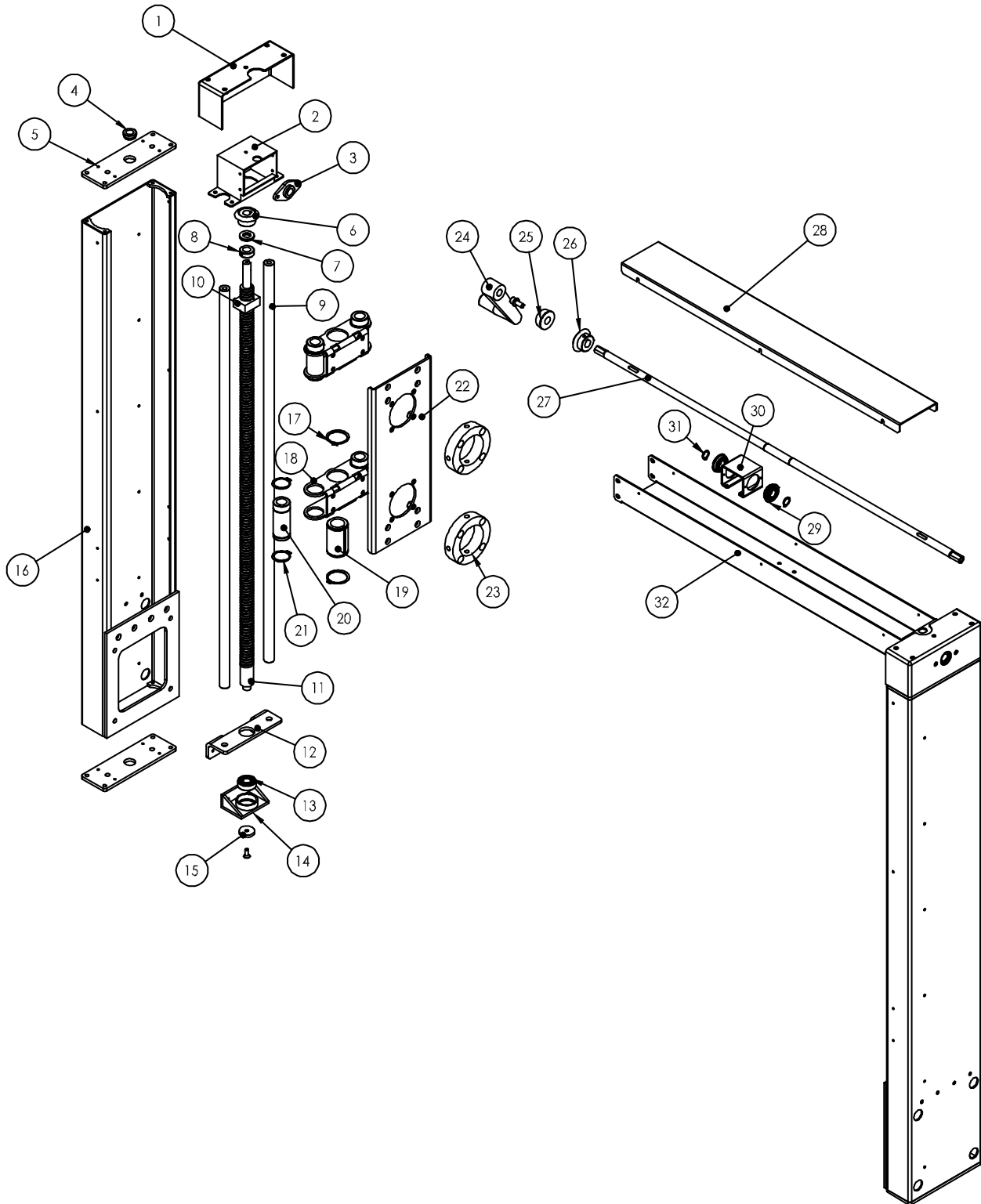

ITEM	PART NO.	DESCRIPTION	REFERENCE	Q'TY
1	5005552	COLUMN COVER FRAME		2
2	5005553	FIX SEAT		2
3	5005554	SHAFT SEAT		2
4	5030904	COPPR RING	P02-0088800	2
5	5005555	TOWER FRAME COVER		4
6	5030978	GEAR (POM)M=1.5,T=30	P0701-0004400	2
7	5005556	BEARING AXK1528	P1104-18AXK15280	2
7	5005557	WASHER AS1528	P1104-19AS15280	4
8	5005558	SWITCH CAM	P02-0047800	2
9	5005559	SHAFT	P02-0073900	4
10	5005560	SCREW (RIGHT)	P06-0073300	1
10	5005561	SCREW (LEFT)	P06-0073400	1
11	5001850	COLUMN SCREW (RIGHT)	P02-007370A	1
11	5001851	COLUMN SCREW (LEFT)	P02-007380A	1
12	5005562	FIX SEAT	P01-0125900	2
13	5030971	BEARING 6202ZZ(CWB)	P1104-026202ZZ0	2
14	5005563	COLUMN BEARING SEAT		2
15	5005564	WASHER		2
16	5005565	COLUMN	P01-0125700	2
17	5030850	C-RIGN S-40	P1105-0140B	4
18	5005566	BRACKET		4
19	5001847	SCREW (RIGHT)	P02-007410A	1
19	5001848	SCREW (LEFT)	P02-007420A	1
20	5031070	LINEAR MOTION BEARING LM-20UU	P1104-01200	8
21	5031081	C-RING S-32	P1105-0132B	8
22	5005567	BRACKET BASE		2
23	5005568	SWITCH CAM	P02-0074300	4
24	5030913	CRANK HANOLE	P1112-0000300	1
25	5031109	HANDLE RING	P06-0022600	2
26	5030936	GEAR (S45C) M=1.5, T=30	P0701-0003000	2

48 Parts Lists

ITEM	PART NO.	DESCRIPTION	REFERENCE	Q'TY
27	5005569	TRANSMISSION SHAFT	P02-0074000	1
28	5005570	COVER FRAME (TOP)		1
29	5005571	BEARING 6002ZZ-NR(CWB)	P1104-076002ZZ0	2
30	5005572	FIX SEAT		1
31	5005573	C-RINGS-15	P1105-0115B	2
32	5005574	COVER FRAME		1

Flap Guide and Upper Tape Head Seat Assembly

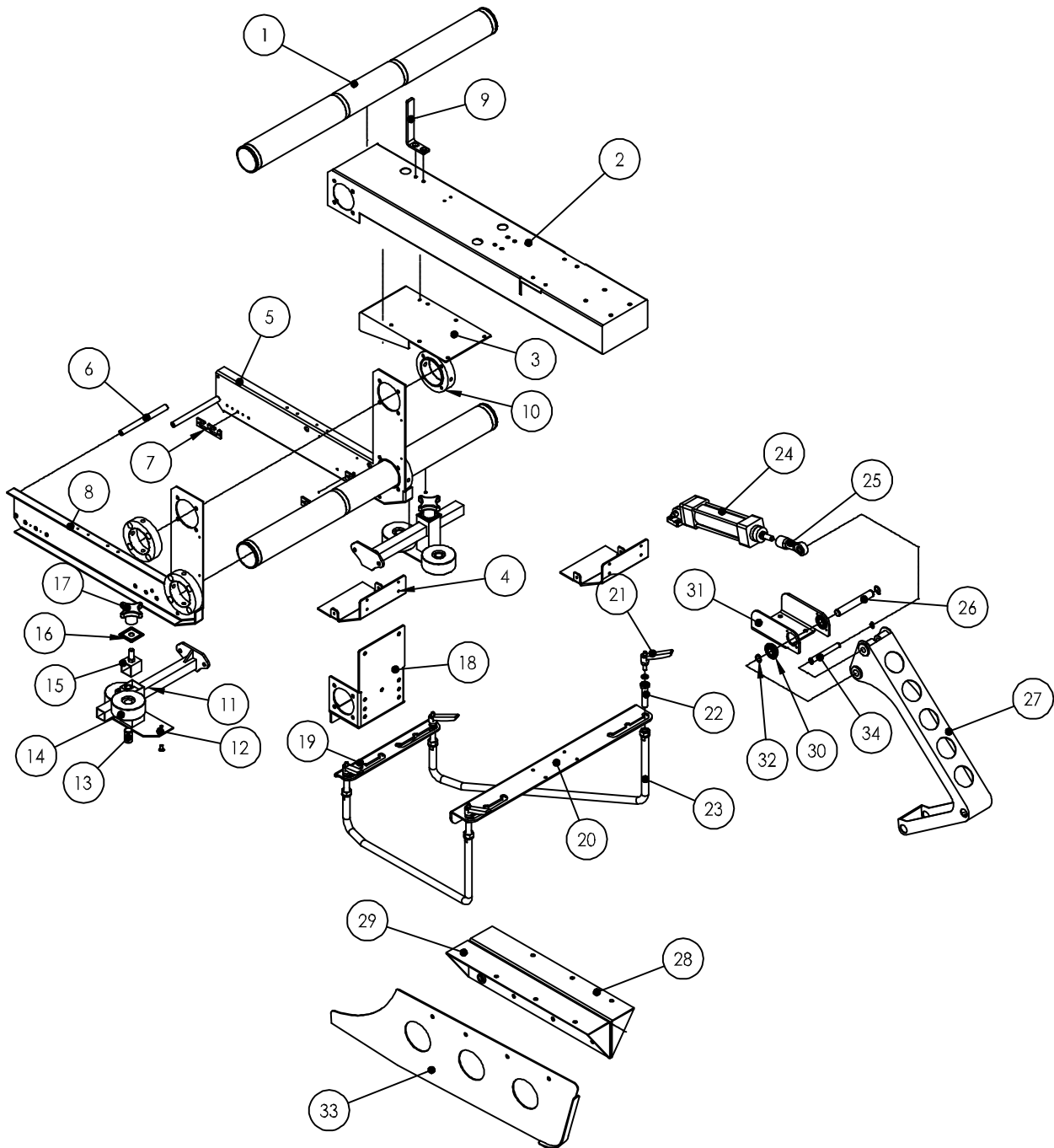

ITEM	PART NO.	DESCRIPTION	REFERENCE	Q'TY
1	5005576	SUPPORT BAR	P02-0074400	2
2	5005577	FOLDING DEVICE SEAT		1
3	5005578	SUPPORT PLATE		1

50 Parts Lists

ITEM	PART NO.	DESCRIPTION	REFERENCE	Q'TY
4	5005579	GUIDE PLATE		1
5	5005580	UPPER TAPE HEAD SEAT (LEFT)		1
6	5005581	CONNECT BAR	P02-0069400	2
7	5005582	B PLATE		4
8	5005583	UPPER TAPE HEAD SEAT (RIGHT)		1
9	5005584	TUBE FIXED SEAT		1
10	5005585	FIXED RING	P02-0074300	4
11	5005586	COMPRESSION ROLLER BAR		2
12	5005587	COMPRESSION ROLLER SEAT		2
13	5005588	COMPRESSION ROLLER SHAFT	P02-0078600	4
14	5005589	COMPRESSION ROLLER	P06-0022400	4
15	5005590	KNOB SCREW		2
16	5005591	LOCKING BRACKET		2
17	5005592	HANDLE KNOB M10x63	P1113-0003900	2
18	5005593	CONNECT SEAT		1
19	5005594	FOLDING DEVICE SEAT		1
20	5005595	FOLDING DEVICE BRACKET		1
21	5005596	FIXED HANDEL	P1112-0000400	4
22	5005597	FIXED SCREW	P02-0069100	4
23	5005598	FOLDING DEVICE	P02-0069000	2
24	5005599	ISO CYLINDER MCQV-11-40-100	P0402-0001400	1
25	5005600	ROD END PHS12EC M12x1.25	P1104-060000500	1
26	5005601	ARM SHAFT	P02-006890A	1
27	5005602	FOLDING ARM		1
28	5005603	FLAP DIVIDER SUPPORT		1
29	5005604	FLAP DIVIDER SUPPORT		1
30	5005605	BEARING	P1104-076002ZZ0	1
31	5005606	FIXED SEAT		1
32	5005607	FIXED PIN	P02-0074500	1
33	5005608	FLAP DIVIDER		1
34	5005609	CYLINDER CONNECT SHAFT	P02-006880A	1

Machine Body

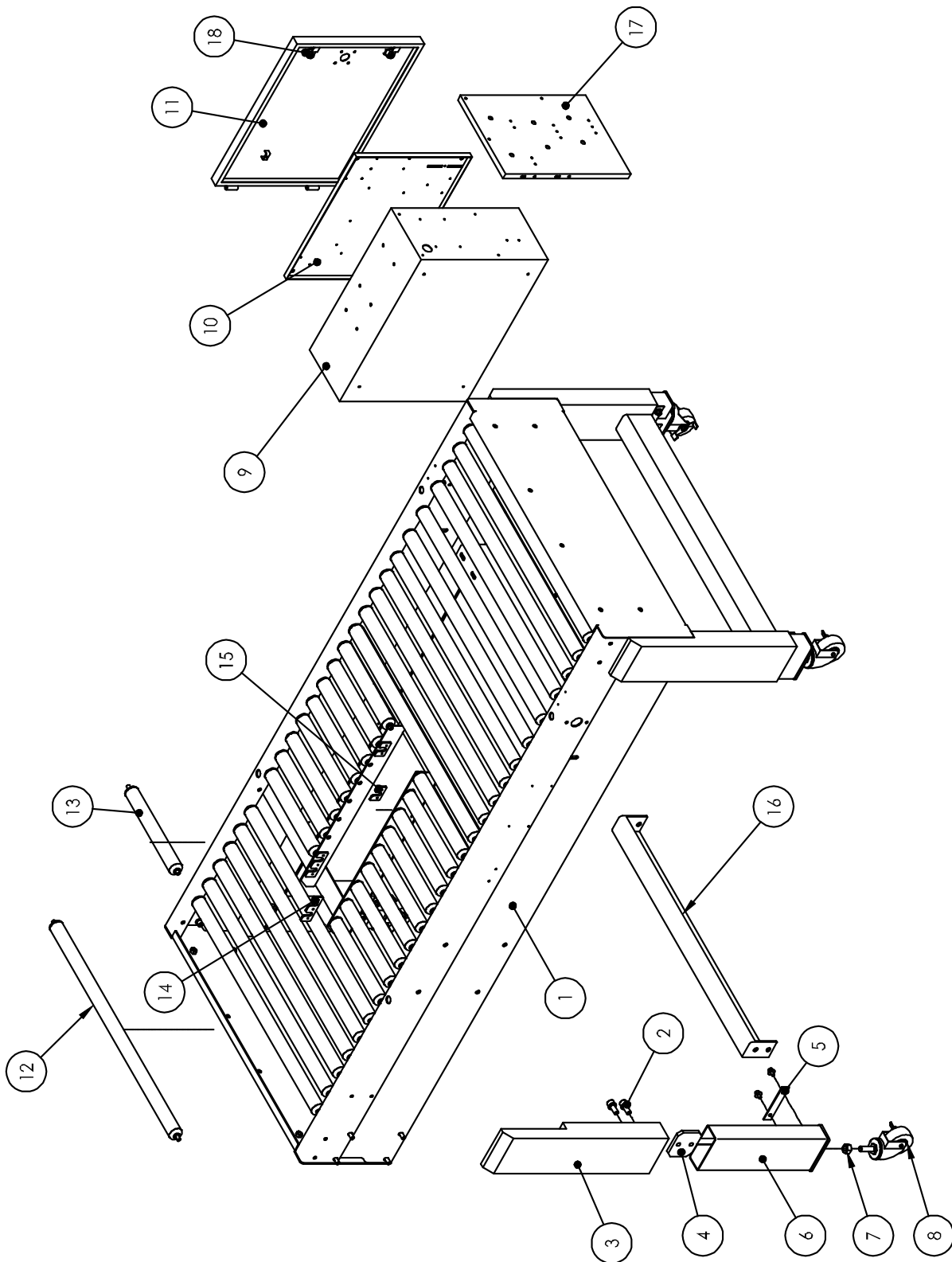

52 Parts Lists

ITEM	PART NO.	DESCRIPTION	REFERENCE	Q'TY
1	5005611	MACHINE FRAME		1
2	5030480	SCREW M6*12L	P1101-0906012AN	8
3	5005612	MACHINE LEG		4
4	5005613	CLAMP		4
5	5005614	FEXED PLATE		4
6	5005615	ADJUSTABLE LEG		4
7	5005616	NUTN 1/2"	P1102-01B4AZ	4
8	5001912	CASTER	P1107-0000300	4
9	5005617	CONTROL BOX		1
10	5005618	WIRING PLATE		1
11	5005619	CONTROL BOX DOOR		1
12	5005620	ROLLER(LONG)	P08-0005000	22
13	5005621	ROLLER(SHORT)	P08-0004900	18
14	5005622	B-PLATE		2
15	5005623	A-PLATE		2
16	5005624	SUBSIDYLEG		2
17	5005625	RADIOTUBE PLATE		1
18	5005626	LOCK	P1118-010000100	2
18	5005627	KEY	P1118-020000100	2
18	5005628	PLATE	P1118-030000100	2

Infeed Index Roller Table

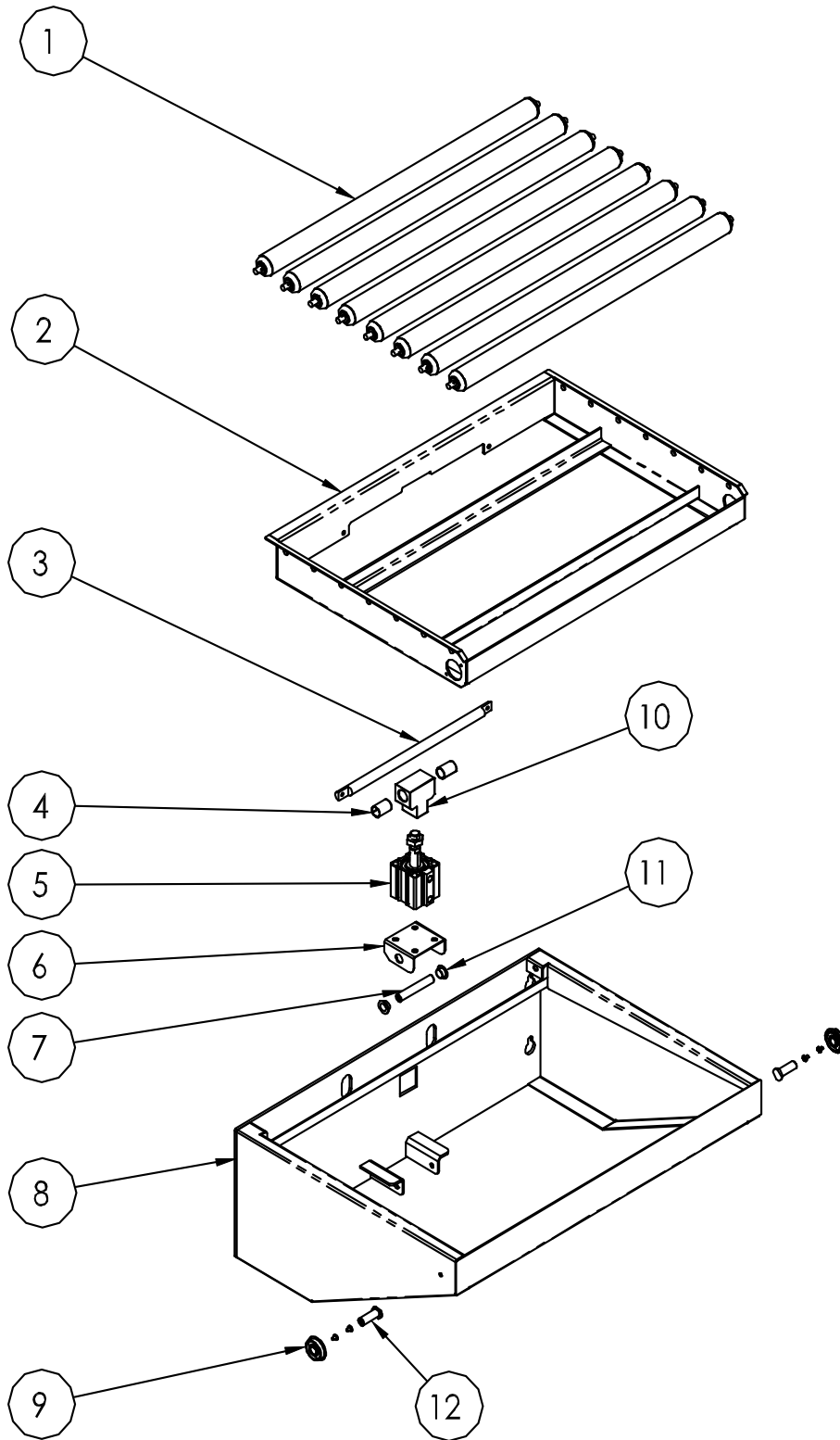

ITEM	PART NO.	DESCRIPTION	REFERENCE	Q'TY
1	5005652	ROLLER	P08-0005100	8
2	5005653	ACTIVE TABLE		1
3	5005654	SUPPORT SHAFT	P02-0363300	1
4	5005655	BUSHING	P1104-0315250	2
5	5005656	CYLINDER	P0402-0007400	1
6	5005657	CYLINDER FIX PLATE		1
7	5005658	PIVOT SHAFT	P02-0363500	1
8	5005659	FRAME	P01-0615500	1
9	5005660	BEARING	P1104-076201ZZ0	2
10	5005661	CYLINDER SEAT	P02-0394800	1
11	5005662	BUSHING	P1104-0312060	2
12	5005663	SHAFT	P02-0363400	2

Tape Head — Refer to Tape Head User Guide

Refer to the parts illustrations and listings in the Tape Head User Guide provided with the tape head for identification and part numbers of tape head parts..

Options

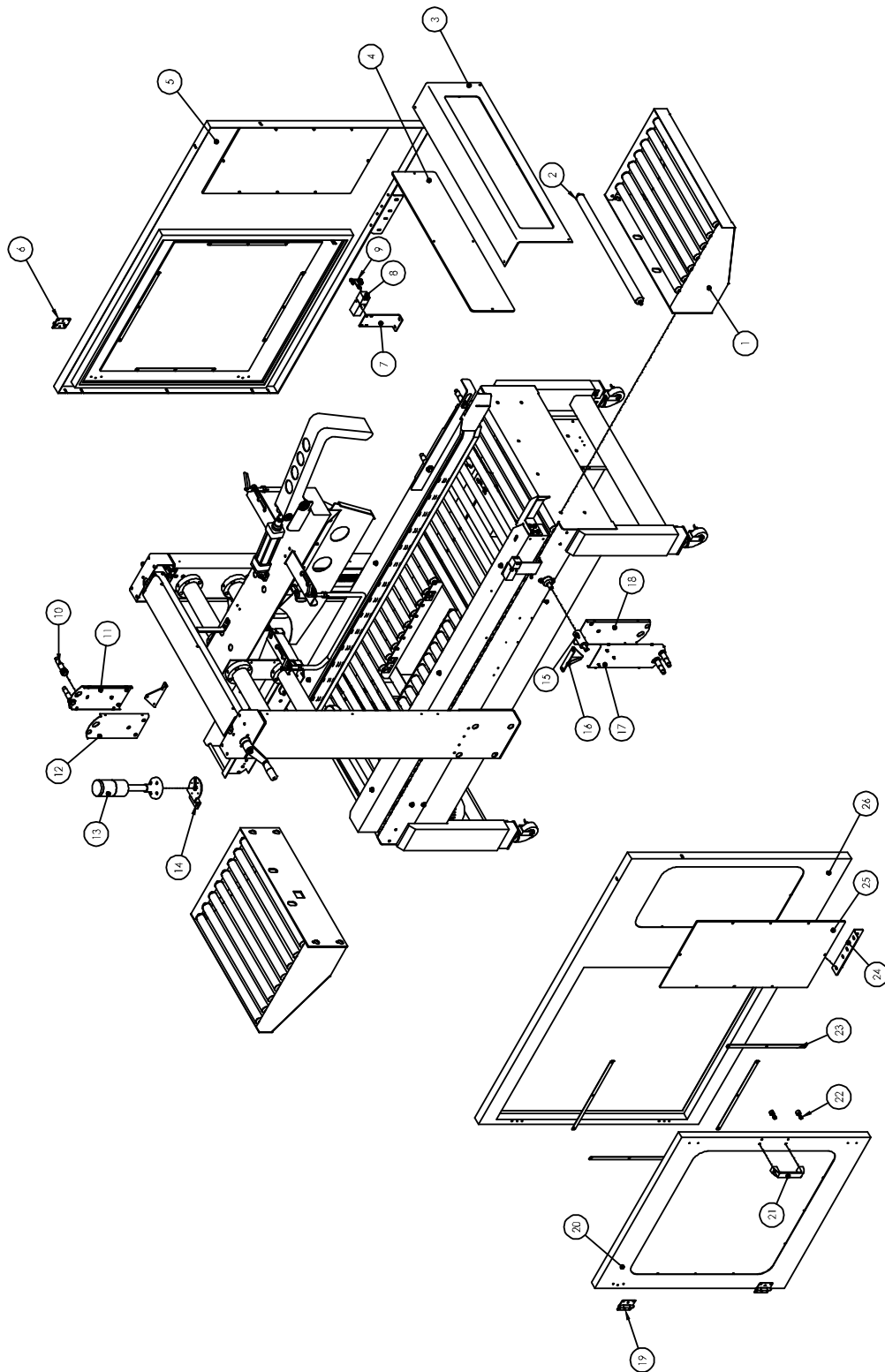

56 Parts Lists

ITEM	PART NO.	DESCRIPTION	REFERENCE	Q'TY
1	5005630	INFEEED/OUTFEED TABLE FRAME	CC430100?	2
2	5005631	ROLLER (SHORT)	P08-0005100	16
3	5005632	DOOR SUPPORT		1
4	5004178	ACRYLIC DOOR	P06-0046100	1
5	5005633	SAFETY DOOR FRAME (R)		1
6	5005634	HINGE (L)		1
7	5005635	SAFETY SWITCH SEAT		2
8	5002208	SAFETY SWITCH TZ-93BPG	P0311-020000100	2
9	5030820	SAFETY SWITCH KEY TZ93-K3	P0311-030000100	2
10	5030731	PHOTO EYE SENSOR	P0302-020000600	4
11	5005636	PHOTO EYE SENSOR SUPPORT (INNER)		1
12	5005637	PHOTO EYE SENSOR SUPPORT (OUTTER)		1
13	5005638	ALARM LIGHT SET	P0312-010001900	1
14	5005639	ALARM LIGHT SEAT		1
15	5005640	EXTENDED SHAFT BUSH	P02-0088900	2
16	5005641	FIXED SUPPORTING SEAT		2
17	5005642	PHOTO EYE SENSOR SUPPORT (INNER)		1
18	5005643	PHOTO EYE SENSOR SUPPORT (OUTTER)		1
19	5005644	HINGE (R)		2
20	5005645	SAFETY DOOR		2
21	5030817	DOOR HANDLE	P1112-0000700	2
22	5030819	MAGNET	P1106-020000100	4
23	5005646	PLATE		12
24	5005647	SUPPORTING PLATE		2
25	5005648	ACRYLIC DOVER	P06-0010400	2
26	5005649	SAFETY DOOR FRAME (L)		1

Appendix A: Electrical Schematic

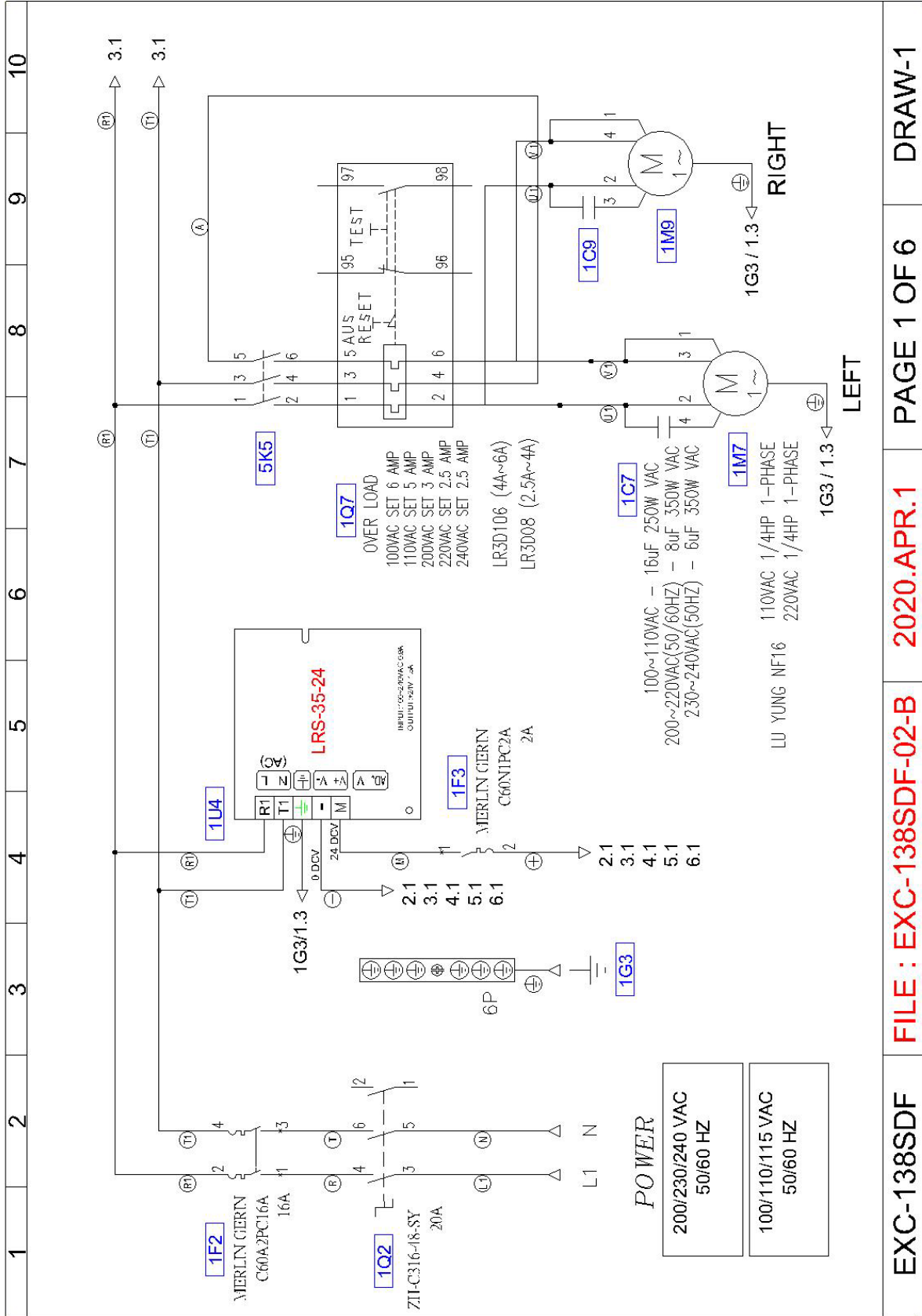

Electrical Schematic Continued

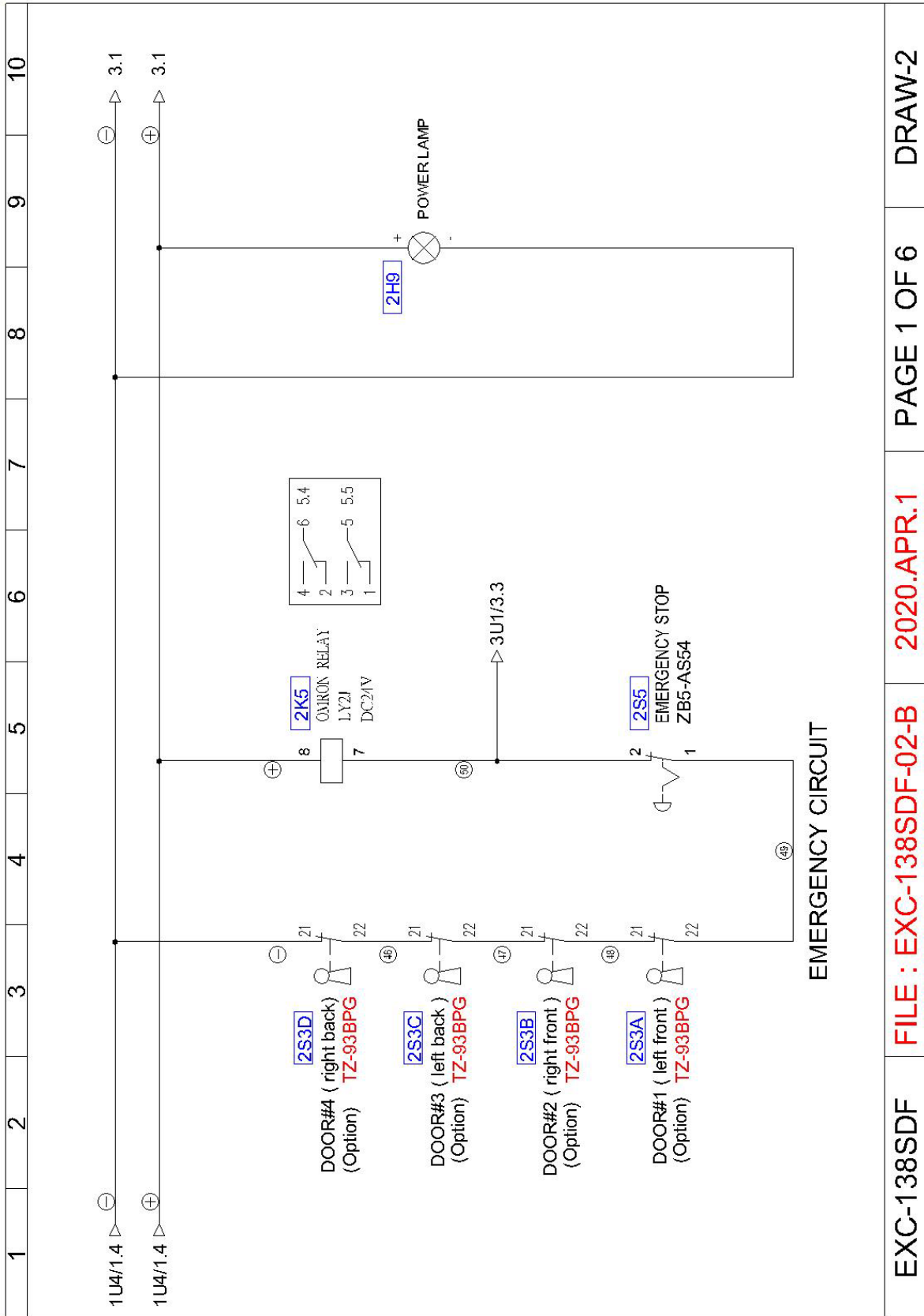

Electrical Schematic Continued

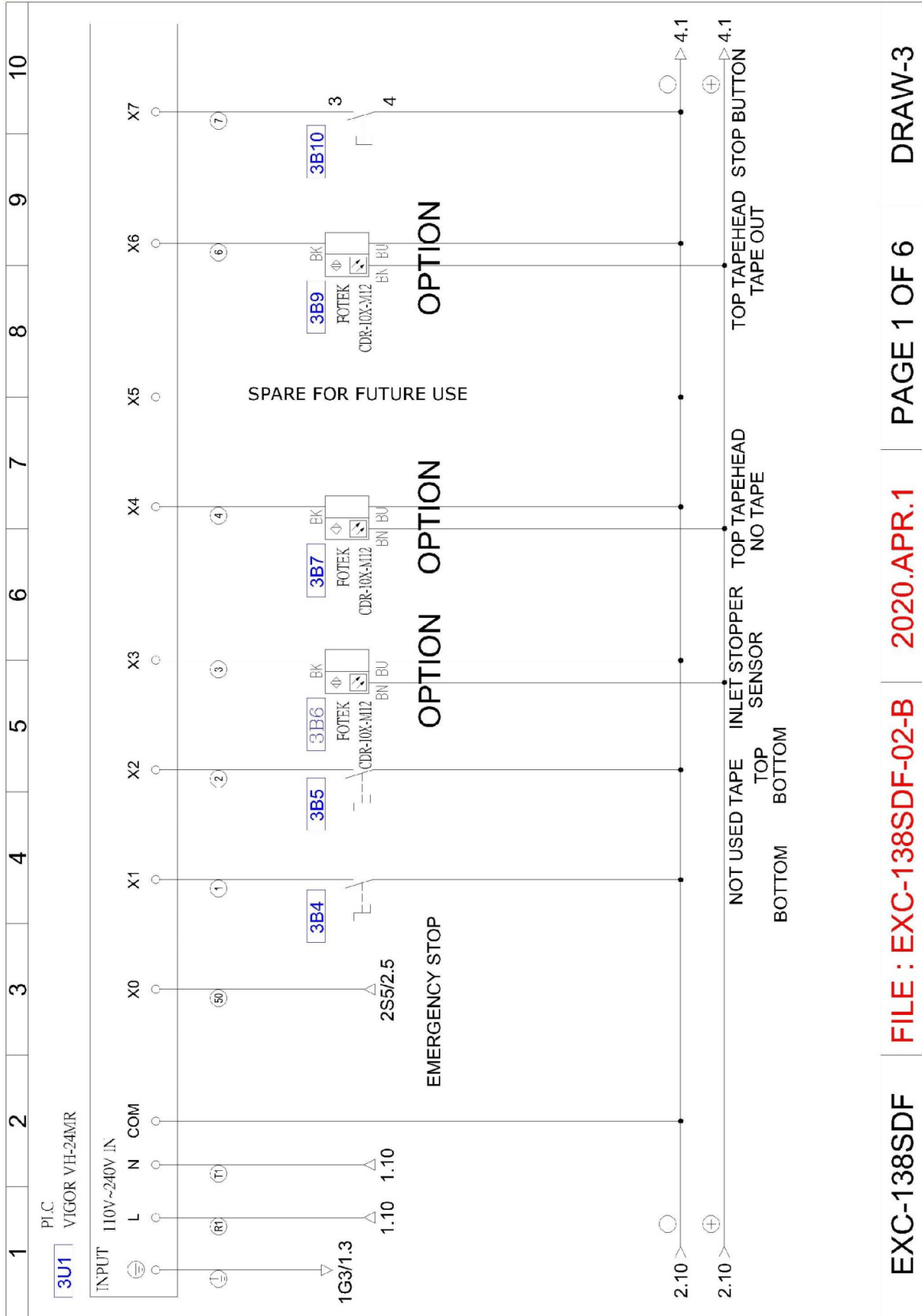

Electrical Schematic Continued

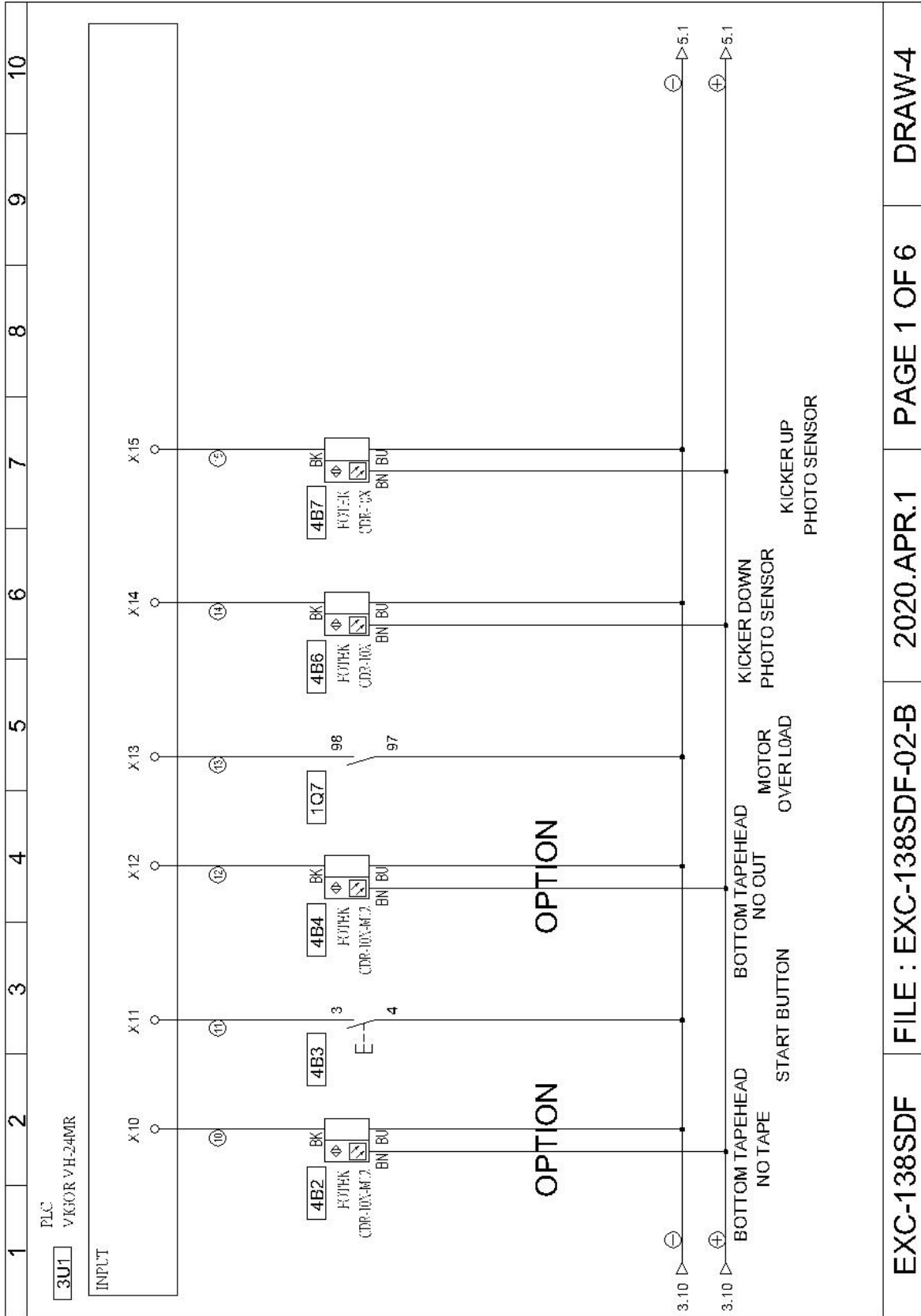

Electrical Schematic Continued

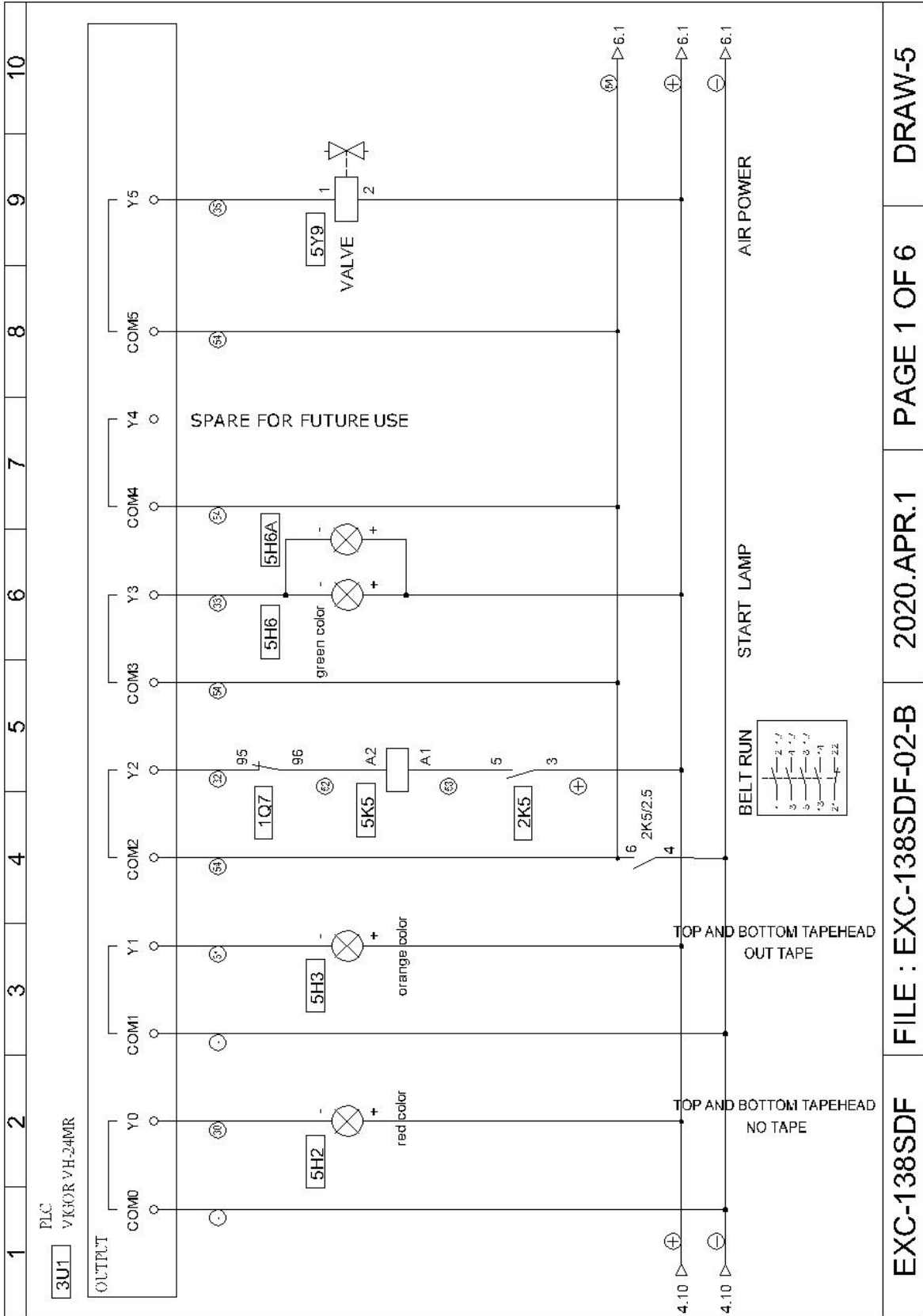

EXC-138SDF

FILE : EXC-138SDF-02-B

2020.APR.1

PAGE 1 OF 6

DRAW-5

Electrical Schematic Continued

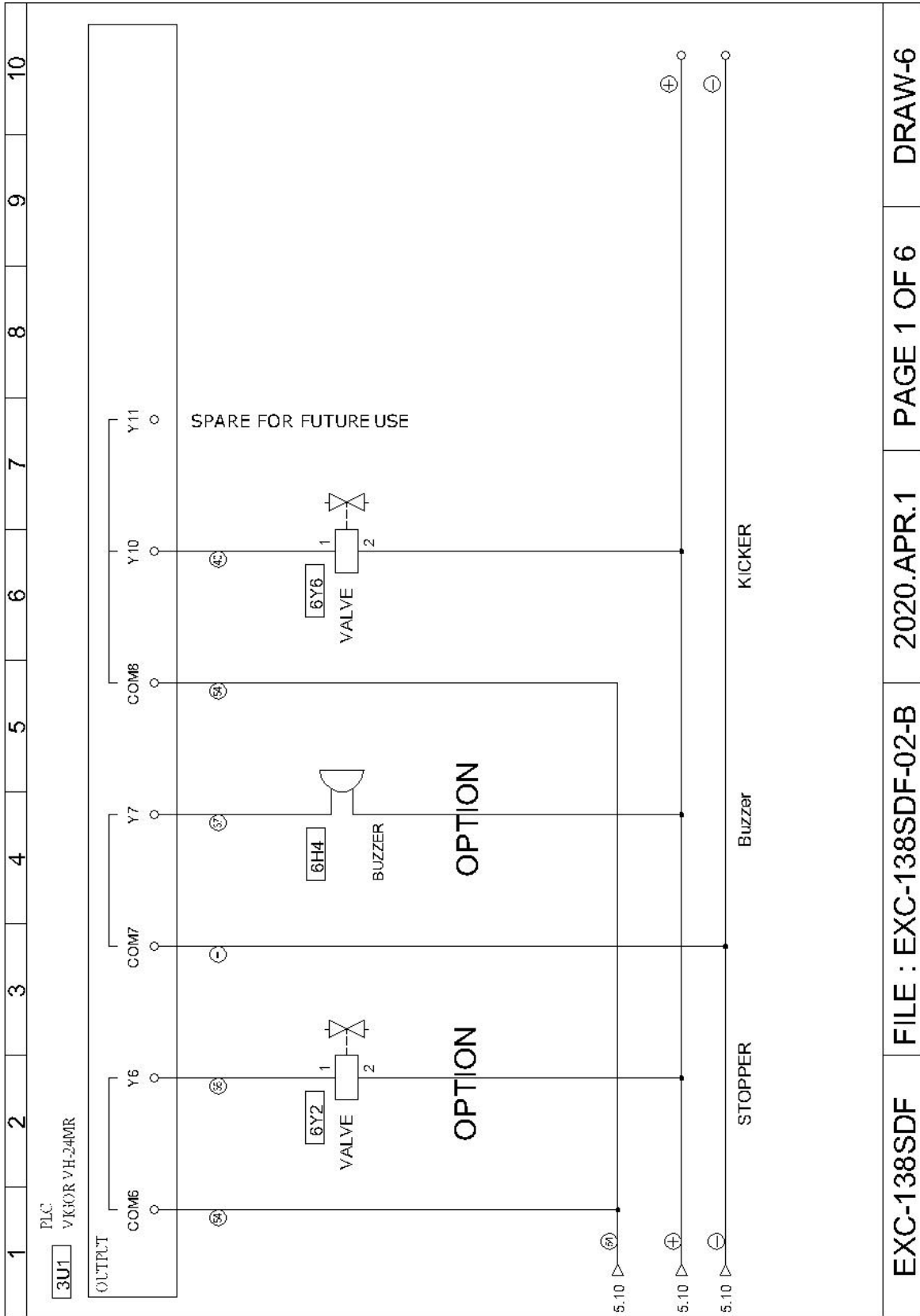

Warranty Statement

SB-2/3EX-Automatic Case Taper

Warranty Statement

Eastey warrants that all of the products it ships will be in good working order and free from defects in material and workmanship and will conform to the published specifications for that product.

Warranty Period

Drive motor(s): 1 year

Gear reducer: 1 year

Tapehead: 1 year (Except for moving parts which are subject to normal wear, tear and replacement which are warranted to be free from defects in material and workmanship.)

All other parts: 1 year (Except for moving parts which are subject to normal wear, tear and replacement which are warranted to be free from defects in material and workmanship.)

Taping Quality

Taping quality achieved in a given application is dependent on the installation, the material handling, and the maintenance provided. Eastey makes no warranty that the print quality achieved in an application will be the same as that achieved on a test piece in our laboratory.

Shipping Policy

Customer pays all incoming shipping. If the item is defective and under warranty, Eastey pays return shipping charges for least costly method. If expedited shipping is desired, customer must furnish his shipping account and shipping fees will be charged to that account.

Warranty Verification

If you conclude that a product may be defective and may be covered by warranty, obtain a Return Material Authorization number by calling our technical support number (toll free at 1-800-835-9344, or 763-428-4846 or Fax 763-795-8867 or e-mail info@eastey.com). Once an RMA number has been obtained, return the defective item to Eastey. Eastey will analyze the product and, if found to be defective, we will, at our option, replace or repair the item. If the item is found to not be eligible for warranty, you will be notified and may decide on disposition. Defective products will be replaced or repaired as promptly as possible.

Warranty Eligibility

The warranty provided by Eastey is only to the original buyer.

Limited Warranty

THE ABOVE WARRANTY IS EXCLUSIVE AND IN LIEU OF ALL OTHER WARRANTIES, WHETHER EXPRESSED OR IMPLIED, INCLUDING THE IMPLIED WARRANTIES OF MERCHANTABILITY, FITNESS FOR A PARTICULAR PURPOSE AND NONINFRINGEMENT.

Disclaimer of Damages

REGARDLESS OF WHETHER ANY REMEDY SET FORTH HEREIN FAILS OF ITS ESSENTIAL PURPOSE, IN NO EVENT WILL EASTEY BE LIABLE FOR ANY SPECIAL, CONSEQUENTIAL, INDIRECT OR SIMILAR DAMAGES, INCLUDING LOST PROFIT OR LOST OPPORTUNITIES OF ANY TYPE ARISING OUT OF THE USE OR INABILITY TO USE THESE PRODUCTS EVEN IF EASTEY HAS BEEN ADVISED OF THE POSSIBILITY OF SUCH DAMAGES.

Customer Support

Eastey Technical Service

For help setting up or operating the SB-2/3EX-AUTO Automatic Case Taper, please contact Eastey Technical Service at one of the numbers listed below.

Toll-Free Phone	800-835-9344
Phone	763-428-4846
Fax	763-795-8867
E-mail	info@eastey.com
Web	www.eastey.com

Thanks again for your purchase of Eastey products. We are pleased to be a part of your packaging needs.



EASTEY®